



**Scotts Valley Water District
Water System
Standard Specifications**



Section 1

Technical Specifications

Section 2

Material Specifications

Section 3

Standard Details



RESOLUTION 08-11 APPROVED APRIL 14, 2011

AMENDED OCTOBER 12, 2017

AMENDED NOVEMBER 14, 2019

AMENDED NOVEMBER 13, 2025

Scotts Valley Water District
2 Civic Center Drive
Scotts Valley, CA
www.svwd.org

Table of Contents

1	SECTION 1 TECHNICAL SPECIFICATIONS	1
1.1	General Provisions	1
1.2	Site Conditions	7
1.3	Excavation.....	12
1.4	Installation of DI and PVC Pipe	16
1.5	Installation of Steel Pipe	19
1.6	Installation of Appurtenances	21
1.7	Backfill and Paving.....	31
1.8	Removal and Abandonment.....	34
1.9	Pressure and Leakage Testing.....	36
1.10	Disinfection and Testing.....	38
1.11	Work on the Existing System	41
2	SECTION 2 MATERIAL SPECIFICATIONS	43
2.1	General	43
2.2	Pipe	44
2.3	Fittings.....	47
2.4	Joint Restraints	49
2.5	Valves	51
2.6	Appurtances	55
2.7	Backfill & Pavement	58
2.8	Miscellaneous	60
3	SECTION 3 STANDARD DETAILS.....	61
	Detail 1 Service Connection	62
	Detail 2 Meter Box Installation	63
	Detail 3 1-inch and Smaller Multiple Branched Service Installation	64
	Detail 4 Retrofit Combination 2-inch Fire and Domestic Service Installation.....	65
	Detail 4b Combination Fire and Domestic Service installation 2-Inch and Smaller	66
	Detail 5 2-inch and Smaller Service Installation.....	67
	Detail 6 3-inch or 4-inch Service Installation	68
	Detail 8 2-inch and Smaller Backflow Prevention Assembly Installation	69
	Detail 9 Standard 4-inch and Larger Fire Service Installation	70
	Detail 9a Vertical 2-inch and Smaller Fire Service BFD Installation.....	71
	Detail 10 Fire Hydrant Installation.....	72
	Detail 11 Gate Valve Installation	73
	Detail 12 Valve Box Lid Markings	74
	Detail 13 Valve Box Installation.....	75
	Detail 14 Standard Service Lateral Trench	76

Detail 15 Standard Water Main Trench	77
Detail 16 Sub-Standard Water Main Trench	78
Detail 17 System Connection (Tie in)	79
Detail 18 Joint Restraint Installation	80
Detail 19 Thrust Block Installation	81
Detail 20 Traffic Bollard Installation	82
Detail 21 Sample Station Installation	83
Detail 22 Chlorination Tap Installation	84
Detail 23 Blow Off Installation	85
Detail 24 Air Valve Installation	86
Detail 25 Below Grade Air Valve Installation	87
Appendix 1 Hydrant Installation Permit Requirements	88

Section 1 Technical Specifications

1.1 General Provisions

1.1.1 General

The Technical Specifications, Material Specifications and Standard Details herein are intended to cover the design, construction and testing of water distribution facilities owned by the Scotts Valley Water District (SVWD or District).

1.1.2 Scope

The purpose of Part I Standard Technical Specifications is to set forth the general criteria to be used in the design, construction and testing of water mains and appurtenances within the SVWD service area. Any deviation from these standards must be supported in writing and approved by SVWD.

SVWD reserves the right to direct or deny use of installations that do not conform to the Standard Specifications set forth in these Technical Specifications, Material Specifications and Standard Details.

1.1.3 Definitions

Wherever the following words are used in these specifications, they shall have the following meanings.

City	The City of Scotts Valley, including City of Scotts Valley, Department of Public Works, City of Scotts Valley Police Department, and other City of Scotts Valley departments, agencies, or the agents thereof.
County	Santa Cruz County
Contractor	The person, firm, company, corporation or authorized agent of such who enters into an agreement with another person, firm, company, corporation, city, municipality, or District to build infrastructure which will become the property of the SVWD.
Contract Documents	All documents incorporated into the construction contract in whole or by reference which have been approved by the Engineer.
Manager	The General Manager of the Scotts Valley Water District.
Engineer	The General Manager or Assistant General Manager of the Scotts Valley Water District, acting personally or through thier authorized representatives.
Install	Provide complete in place; "furnish and install."
Maximum Density	The density of backfill materials obtained by ASTM D1557.
Non Potable Line	Any pipe conveying sewage, treated sewage, storm drainage, recycled water, untreated water, any fuel including natural gas, or any hazardous fluid.
Owner	The property owner or the owner's authorized agent. The party specified in the Will Serve Letter to own the service of the approved improvements pursuant to the Will Service letter specified service.
Relative Compaction	The percentage of the Maximum Density of backfill material as obtained by ASTM D1556 or ASTM D6938.
SVWD, District	Scotts Valley Water District
Fire District	Scotts Valley Fire Protection District

1.1.4 Abbreviations

Wherever the following abbreviations appear in these specifications they shall refer to the following meanings.

AC	Asphalt Concrete	HDPE	High Density Polyethylene
A-C	Asbestos Cement	HORIZ	Horizontal
ACI	American Concrete Institute	IP	Iron Pipe
ADU	Accessory Dwelling Unit	IRR	Irrigation
ARV	Air Release Valve	LTS	Length To Suit
ASTM	American Society of Testing Materials	MAX	Maximum
AWWA	American Water Works Association	MG/L	Milligrams per Liter
CalTrans	California Department of Transportation	MIN	Minimum
Bacti	bacteriological	MIP	Male Iron Pipe
CI	Cast Iron	MJ	Mechanical Joint
CIP	Cast Iron Pipe	(N)	New
CL	Centerline, Class	No	Number
CLSM	Controlled Low Strength Material	NSF	National Sanitation Foundation International
COMP	Compression	NTS	Not to Scale
CONC	Concrete	OC	On Center
Corp	Corporation	OL	Open Left
CTS	Copper Tube Size	OR	Open Right
CY	Cubic yard	OSHA	Occupational Safety and Health Administration
DCDA	Double Check Detector Assembly	PL	Property Line
DEPT	Department	PPM	Parts per Million
DIA, Ø	Diameter	PRV	Pressure Reducing Valve
DI	Ductile Iron	PSF	Pounds per Square Foot
DIP	Ductile Iron Pipe	PSI	Pounds per Square Inch
DOM	Domestic	PVC	Polyvinyl Chloride
(E)	Existing	RES	Residential
EA	Each	REQ'D	Required
EW	Each Way	RP	Reduced Pressure Principle Detector Assembly
FIG	Figure	RS	Riveted Steel
FIP	Female Iron Pipe	SVWD	Scotts Valley Water District
FLG	Flange	SF	Square Feet
FS	Fire Service	SFD	Single Family Dwelling
FT	Feet	STD	Standard
GA	Galvanized	TYP	Typical
GP	General Physical	USA	Underground Service Alert
		VERT	Vertical
		WS	Welded Steel

1.1.5 Specification References

All references to other specifications, standards, and details found in these specifications shall refer to the latest edition of that reference, unless noted otherwise.

Each section within Part I of these specifications implicitly refers to the applicable section(s) in Part II – Material Specifications.

“Scotts Valley Water District "Ordinance No. 119-96, Rates, Rules, and Regulations” is incorporated herein by reference.

The City of Scotts Valley Standard Details and County of Santa Cruz Design Criteria are supplemental to these specifications. In the event of a conflict between the supplemental materials and these specifications, the requirements set forth in these specifications shall prevail in matters of water improvements.

Wherever reference is made to the "State Standard Specifications" or to “Caltrans Specifications” reference shall be to the specifications entitled, "State of California, Department of Transportation, Standard Specifications,"

Wherever "SVWD Backflow Protection Policy” appears in this document, reference shall be made to sections of Ordinance No. 119-96, Rates, Rules, and Regulations addressing backflow and the Scotts Valley Water District Backflow Protection Policy Statement.

1.1.6 Standard Details

The SVWD Standard Details are to be followed in the installation of water mains and appurtenances. The Standard Details form Section 3 of these specifications.

1.1.7 Water System Plans

Plans showing the size, type and location of infrastructure to be installed and other pertinent details shall be prepared for all water system improvement projects. All plans used for construction shall bear the seal and signature of a civil engineer registered in the State of California. Plans shall be approved by the Engineer prior to the start of actual construction.

Electronic copies of plans shall be submitted, conforming to the drafting standards provided by the Engineer. Plans and surveys shall be based on the North American Datum of 1983. Elevations shall be based on the North American Vertical Datum of 1988 or other as approved by the Engineer. The datum, benchmark(s), and horizontal control points used shall be noted on the plans.

1.1.8 Development Plan Submittal Requirements

Developments which require new water service, change of an existing service, relocation of existing water facilities, or which otherwise affect the water system shall be approved in advance by the Engineer.

Two sets of check prints shall be submitted for the Engineer to redline. Plans shall clearly show locations of all existing and proposed utilities and appurtenances, their material, class, diameter, and indicate depths at crossings and connection points. One set shall be returned to the developer with the Engineer's comments.

Once plans have been approved by all applicable agencies, the developer shall submit five printed sets and an electronic copy of final plans for SVWD use.

1.1.9 Submittals

Prior to construction, and with sufficient time to verify compliance, the Contractor shall submit two copies of cut sheets and specifications for all materials proposed to be used in the construction of the project or which will become the property of the SVWD. The Engineer shall approve or reject the submittals in writing based upon conformance with these specifications and the specifications referenced herein. No material shall be used for construction which has not been approved by the Engineer.

1.1.10 Permitting Requirements

Prior to the commencement of work on any District owned facility or within the public right-of-way, the Contractor shall obtain all applicable permits and approvals from the District, the City, the County, and any applicable permits from other regulatory agencies unless already obtained by SVWD

1.1.11 Licenses

The Contractor performing the work shall be on the District's Approved Contractors List or shall provide a completed Approved Contractor's Application to the Engineer no less than two working days prior to scheduling the work. Licensure and insurance requirements are specified on the Approved Contractor Application. Approved Contractor's shall maintain the required licensure and insurance for the duration of the work.

The Contractor performing the work shall possess State issued contractors license(s) as required by law and shall furnish satisfactory proof to the Engineer, upon request, that such licenses are in effect during the entire period of construction.

The Contractor performing the work shall possess liability, automotive, and workers compensation insurance as required by the District. Scotts Valley Water District employees, and agents of the Scotts Valley Water District, shall be listed as additional insured under the Contractor's liability coverage.

The Contractor performing the work shall be experienced in the type of work to be performed. No work shall commence until the Engineer has approved the Contractor and all subcontractors.

1.1.12 Rights-of-Way

Where the location of the facility is not in public property, the developer or the SVWD, at the option of the SVWD, shall obtain a right-of-way and the title shall be vested in the SVWD.

1.1.13 Inspection

All work done for SVWD, to SVWD facilities, or on facilities to be accepted for ownership by SVWD, shall be subject to rigid inspection. The Contractor shall provide safe access to all parts of the work as necessary for the Engineer to confirm compliance with these specifications and to record measurements. Work or materials that do not conform to the specifications may be rejected at any stage of the work. The Contractor shall remove and rebuild, at the Contractors expense, any part of the work that includes substandard materials or has been improperly executed.

1.1.14 Advance Notification and Scheduling

The Contractor shall provide a work schedule to the Engineer and receive approval to proceed not less than 2 working days prior to the commencement of work. The Contractor shall alert the Engineer of any changes to the work schedule. The District reserves the right to cancel the work at any time based on inspector availability.

Whenever work done under these specifications is to be done on Saturday, Sunday, an SVWD holiday or between 3:30 pm and 8:00 am, the Contractor shall pay all costs to the District of such extra inspection. Prior approval by the Manager must be obtained two working days in advance of such work.

1.1.15 Authority of Engineer

On all questions concerning the acceptability of materials or equipment, the classification of material, the execution of the work and conflicting activities of Contractors performing related work, the decisions of the Engineer shall be final and binding on all parties.

1.1.16 Guarantee and Warranty Period

The Contractor guarantees that any work performed by him/her under the agreement will be performed in the best manner; that any material furnished by him/her will be the best of its class; and, that both work and material will meet fully the requirements of these specifications.

The Contractor agrees that if, within a period of one year after final acceptance of the work any part of the pipeline, other structures, pavement, facilities, or improvements constructed or installed by the Contractor or any subcontractor, fails to perform in accordance with these specifications, the Contractor will, without delay and with the least practical inconvenience and without further costs to the District, repair or replace defective or otherwise unsatisfactory parts of said facilities or pavement and install all additional materials if required, all to the satisfaction of the Engineer. Furthermore, the costs of any damage resulting from a failure of the aforementioned nature within the one year guarantee period shall be borne entirely by the Contractor.

Should the Contractor fail to act promptly in accordance with this requirement, or should the circumstances of the case require repairs or replacement to be made before the Contractor can be notified or can respond to notification, the District may, at its option, make the necessary repairs or replacements or perform the necessary work. The Contractor shall pay to the District the actual cost of such repairs plus standard overhead charges.

The Contractor shall be responsible for the full expense incidental to making good any and all of the above guarantees and agreements. The above guarantees and agreements are covenants and performance of which shall be binding upon the Contractor and his/her sureties.

1.1.17 Lines, Grades, and Alignments

The Contractor shall establish all lines, grades and alignments indicated by the Contract Documents, subject to inspection, review and approval of the Engineer.

1.1.18 Separation Requirements

Water facilities shall be located at such distances from possible sources of contamination to protect public health and safety. Water facilities shall be located at such distances from possibly damaging objects to ensure future serviceability. Unless stated otherwise, all measurements prescribed in this section shall be made to the nearest outside edge of the facilities. All distances are clearances.

1.1.18.1 Separation from Non Potable Lines and Hazardous Facilities

New treated drinking water mains shall be constructed in compliance with The California Code of Regulations Title 22, Division 4, Chapter 16, Article 4, Section 64572.

If conditions require construction at clearances less than those prescribed by the above mentioned code, approval from the California Department of Public Health shall be obtained prior to construction.

Four feet clear horizontal distance shall be maintained between pipe used to convey potable water and pipe used to convey recycled water.

Five feet clear horizontal distance shall be maintained between water service laterals and sanitary sewer laterals. Three feet clear distance shall be maintained between water service laterals and other utility lines.

Joint trenches with water lines and any other utility lines are prohibited.

No new non potable lines shall be constructed such that any of the above separation requirements are violated.

1.1.18.2 Separation From Trees

No water facility shall be installed within 5 feet from the trunk of any tree. Wherever roots two inches in diameter or greater are encountered during the course of construction, such roots shall be protected in place and the facility re-aligned if necessary. Where circumstances do not allow for minor re-alignment, roots may only be cut with the approval of the District. All roots two inches in diameter or larger that are exposed by construction activities shall be protected from damage and drying out.

No tree shall be planted such that above separation requirements are violated.

1.2 Site Conditions

1.2.1 Site Safety

All work shall be planned and conducted with full attention to the safety of drivers, bicyclists, pedestrians, the public, and workers. The Contractor shall institute controls and procedures for the control and safety of all persons at or passing through the job site. Continuous maintenance of the work area is required. Traffic control and safety devices shall be maintained at all times day and night on all work that is not safe for the public until such time as it is made safe. The Contractor shall provide safe access to all parts of the work as necessary for inspection to confirm compliance with requirements and record measurements.

It shall be the Contractor's responsibility to provide for the convenience and safety of District employees, the Contractor's employees, the subcontractor's employees, and the general public in connection with the Contractor's operations. The Contractor shall conform to the rules and regulations pertaining to safety established by the California Division of Industrial Safety. Furnished equipment, materials, and services shall comply with all OSHA standards and regulations and all applicable laws and orders. The Contractor shall provide and maintain throughout the course of construction all temporary public walks, traffic control measures, warning signs, barricades, and other protective means and methods as may be necessary for the protection of the public from injury.

Safety precautions, means, methods, techniques, sequences, or procedures and programs related to safety are the sole responsibility of the Contractor. The Contractor shall also be responsible for compliance with the safety requirements by its subcontractors. The District will not supervise, control, or direct Contractor's safety precautions or programs, or inspect for safety conditions on work site, or of persons thereon, whether Contractor's employees or others. However, the District may notify the Contractor if made aware of a violation of the contract from a safety perspective and may halt work if an imminently dangerous situation is observed. After receipt of such notice, the Contractor shall promptly take corrective action. The District may report the violation to Cal-OSHA or other regulatory agency with jurisdiction and may issue a stop work order for failure to comply with safety requirements. The Contractor shall not make time lost due to any stop order related to safety the basis of a claim for an extension of time or for extra costs or damages.

Until the formal acceptance of the work by the District, the Contractor shall have the charge and care of the work and of the materials used therein, and shall bear the risk of injury, loss, or damage to any part thereof by the action of the elements or from any other cause, whether arising from the execution or from the non-execution of the work. The materials to be used in the work include both those furnished by the District and those furnished by the Contractor, including materials for which the Contractor has received partial payment. Contractor shall protect both finished and unfinished work from damage due to adverse weather at all times at no additional cost to the District. Work that becomes damaged due to the effects of adverse weather prior to District acceptance of the work shall be replaced or repaired to the Engineer's satisfaction at no additional cost to the City.

1.2.2 Traffic Control and Site Access

The Contractor shall provide traffic control as a part of all operations affecting or with the potential to affect any means of transportation utilized by the public, including pedestrian, bicyclist and motorist traffic. The Contractor shall provide all traffic control signage and devices required by these specifications, and provide a sufficient number of competent personnel to operate said devices.

The Contractor shall coordinate traffic control and construction operations such that traffic is monitored and controlled at all times, yet inhibited as little as practicable, and public inconvenience is minimized.

The Contractor may re-route traveled ways, including motor vehicle lanes, bicycle lanes, and sidewalks, only in accordance with a traffic control plan approved prior to construction by the Engineer and City.

The Contractor shall not close traveled ways, including motor vehicle lanes, bicycle or pedestrian routes without the prior approval of the Manager and five working days advance public notification by means of signage and/or advertisement to the satisfaction of the Engineer.

1.2.2.1 Control Devices

The Contractor shall control motorist, bicyclist and pedestrian traffic by placing signs, barricades, and pavement delineators conforming to the California Manual on Uniform Traffic Control Devices and these specifications.

If construction activities block the bike lane, the Contractor shall post "Bike Lane Closed" and "Share the Road" caution signs to warn motorists to slow down and watch for bicyclists and pedestrians. Construction activities or construction signs that block the bikeway should have sufficient sight distance, including night time visibility, to allow cyclists time to merge safely into the car lane. Whenever possible, construction warning signs shall be placed out of bicycle, pedestrian, and vehicular paths of travel.

If it is necessary to close a sidewalk, the Contractor shall install signs which inform pedestrians that the sidewalk is closed and direct pedestrians to a safe alternate route. Barriers in walkways shall include a portion low enough and solid enough to be easily discernible by a cane, guide dog or child. If construction activities or construction signs block pedestrian routes, the Contractor shall establish safe, well-signed detours for pedestrians, which are accessible for wheel chairs, strollers, carts, etc. Detours shall have sufficient warning to allow wheelchairs time to exit the walkway at a prior curb ramp.

If any component in the traffic control system is damaged, vandalized, stolen, displaced or ceases to operate or function as intended, from any cause during the progress of the work, the Contractor shall immediately repair said component to its original condition or replace said component and shall restore the component to its original location.

1.2.2.2 Pedestrian Bridges

Pedestrian bridges of construction approved by the Engineer, shall be installed over the trench at all crosswalks and intersections, and at other points where, in the opinion of the Engineer, traffic conditions make it necessary. Bridges shall not be less than 4 feet in width and shall be provided with hand rails. Transitions between pavement and bridge surface shall be tapered at the edges for pedestrian and wheelchair safety.

1.2.2.3 Site Access During Working Hours

Vehicular and pedestrian access to all businesses, residences, and all property adjacent to the site shall be maintained at all times or provided as needed. If this requirement can be demonstrated to be the cause of extreme construction hardship, alternative coordination and provisions may be implemented with the approval of the Engineer. In general, work shall stop periodically and excavations shall be plated to allow access. Temporary approaches to, and crossings of, street intersections shall be provided and kept in good condition. The Contractor shall make way for emergency vehicles through the work area and to adjoining properties at all times as needed regardless of temporary closure or other traffic controls.

1.2.2.4 Site Access During Non-working Hours

The Contractor shall keep all traveled ways open to the public during nights and weekends throughout the construction period, unless otherwise approved by the Director and five working days advance public notification is provided by means of signage and/or advertisement to the satisfaction of the Engineer.

All holes, trenches, etc., in publicly traveled areas shall either be covered with steel trench plates, or backfilled and paved with temporary pavement or permanent pavement in accordance with the applicable sections of these specifications. Steel plates shall be maintained movement-free at all times with stakes, shims and welds. Plates shall have temporary asphalt compacted around the edges so that transitions are smooth. Temporary asphalt shall be regularly maintained to provide a surface free of potholes and resistant to the intrusion of water into the subgrade.

1.2.3 Site Cleanliness

The Contractor shall keep the construction site in a neat and sanitary condition at all times. All trash and excess excavated material shall be removed from the site as soon as possible and immediately at the request of the Engineer. On or before completion of the work, the Contractor shall remove all temporary structures and leave all areas in a condition satisfactory to the Engineer.

All traveled ways including streets, bikeways, and walkways, shall be swept by power or hand broom at the end of each workday and as needed while open for use by the public. Debris shall be cleared by the end of each workday. All areas accessible to the public shall be kept clean and free of debris at all times.

1.2.4 Site Restoration

The Contractor shall replace in kind or otherwise restore all property damaged or affected by the construction, including street surfaces, sidewalks, striping, markings, signage, curbs, gutters, pipes, conduit, gas, water and other utilities, sewers, monuments, stakes, trees, shrubs, landscaping, and other public or private property to a condition equal to or better than the condition prior to construction. Restoration shall follow construction as the work progresses and shall be completed as soon as possible. Construction signs shall be promptly removed when construction pauses or ends. Final restoration that cannot be performed promptly due to adverse weather conditions may, upon written request that includes a proposed procedure and time schedule, be performed as approved by the Engineer.

1.2.5 Dust Control

During the performance of all work, the Contractor shall assume all responsibility for dust control and shall furnish all labor, equipment, material, and means necessary to carry out proper measures wherever and whenever dust control is necessary to prevent the operations, stockpiles, and staging areas from producing nuisance dust to persons or property.

The District may notify the Contractor if made aware of nuisance dust. After receipt of such notice, the Contractor shall promptly take corrective action. The District may issue a stop work order for failure to comply with dust control requirements. If dust problems should continue, the District may halt construction until Contractor implements such means and methods as to abate all fugitive dust.

No compensation of any kind shall be provided to the Contractor by the District for construction delays due to stop orders related to dust. The Contractor shall not base any damage claims or time extension requests upon any stop order related to dust.

Any claims against the District resulting from fugitive dust shall be borne by the Contractor. Any fines levied to the District as a result of dust caused by the Contractor shall be borne by the Contractor. Such costs may be deducted by the District from any monies due or that will become due to the Contractor under the Contract.

1.2.6 Water Pollution Control

The Contractor shall keep on site and ready at all times during construction all equipment and materials needed to be implemented to ensure the protection of all surface water bodies and sewer and storm drain systems from runoff which may be contaminated by sediment, sawcut slurry or other pollution in the event

of an emergency water facility breakage, trench dewatering activity, or wet weather event that may erode stockpiles or exposed soil areas. The Contractor shall prevent the transport of sediment to storm drains or receiving waters during open channel discharges containing sediment or having the potential to entrain sediments.

The Contractor shall ensure that no water is discharged containing concentrations of pollutants in excess of applicable water quality objectives, or containing substances in concentrations toxic to human, animal, plant, or aquatic life, or containing contaminated ground water. The Contractor shall ensure that no water containing measurable chlorine residual greater than or equal to 0.02 mg/L residual is discharged to any storm drainage system or surface water body.

The Contractor shall not increase the turbidity of receiving waters beyond the following limits: Where natural turbidity is between 0 and 50 Nephelometric Turbidity Units (NTU), increases shall not exceed 20 percent. Where natural turbidity is between 50 and 100 NTU, increases shall not exceed 10 NTU. Where natural turbidity is greater than 100 NTU, increases shall not exceed 10 percent.

Water from trench dewatering operations may be pumped into the sanitary sewer only with prior approval by the Owner of the facility. Such discharge shall not be allowed to cause overflow at any manhole, either upstream or downstream. The Contractor shall be responsible for monitoring of the sewer system during any approved discharge.

The Contractor shall immediately notify the City whenever a discharge of sediment or other pollutants occurs. The Contractor shall either document the discharge characteristics to the satisfaction of the Engineer or pay the District for the costs of monitoring. Upon discovery of an illicit discharge, the Contractor shall promptly take corrective action. The District may issue a stop work order for failure to comply with pollution control requirements. If the discharge should continue, the District may halt construction until Contractor implements such pollution controls.

No compensation of any kind shall be provided to the Contractor by the District for construction delays due to stop orders related to pollution. The Contractor shall not base any damage claims or time extension requests upon any stop order related to pollution caused by the Contractor.

Should the Contractor fail to provide water pollution controls as needed or be negligent in causing the water pollution, the District or other agency may implement emergency pollution control measures. Costs for such mobilization, implementation, materials, reporting, and clean-up shall be borne by the Contractor if responsible for the pollution. Such costs may be deducted by the District from any monies due or to become due to the Contractor under the Contract.

Any claims against the District resulting from pollution shall be borne solely by the Contractor. Any fines levied to the District as a result of pollution caused by the Contractor shall be borne by the Contractor. Such costs may be deducted by the District from any monies due or that will become due to the Contractor under the Contract.

1.2.7 Discovery of Archaeological Resources

Construction activities may lead to the inadvertent discovery of archaeological resources within the project area. These resources may include but are not limited to historical objects, bottles, ceramics, shells, beads, flaked or ground stone tools, bones, human remains, village sites, remains of buildings, or old dump sites unearthed by Contractors in the course of their work activities.

Should the Contractor or subcontractor discover a suspected archaeological resource, the Contractor shall immediately stop excavation in the vicinity of the find, and notify the District. The portion of the excavation in which the discovery was made shall be secured until the discovery can be evaluated. The Contractor shall protect with steel plates and provide access to the discovery site as needed. Work shall not resume in that location until the Contractor receives authorization from the District.

Archaeologists, monitors, and Native American Observers may be retained by the District and may be present during ground disturbing activities associated with the project that occur within the areas determined by the District to be archaeologically sensitive and as needed. Native American observers may be on site during ground disturbing activities associated with the project that occur within probable burial or sacred sites. The contractor shall extend the same access and safety considerations to such archaeology related monitors as is required to be provided to the Engineer. The Contractor must stop excavation at the request of such monitor or Engineer and shall not make time lost due to any stop request related to the evaluation of archaeological resources the basis of a claim for an extension of time or for extra costs or damages unless such delay exceeds 15 minutes in any one incident or more than 25 minutes in any single day's work.

1.3 Excavation

1.3.1 General

The Contractor shall perform all excavation indicated by the Contract Documents or the Engineer. The excavation shall include the removal and disposal of all materials, of whatever nature encountered, including groundwater, abandoned utilities and sub-surface obstructions.

1.3.2 Protection of Existing Facilities

All construction activities in the vicinity of other utility lines, conduits, services, and other structures, or appurtenances thereto, shall be executed in such manner as not to interfere with their safe operation. Proper precautions shall be taken to prevent damage to other utilities.

The Contractor shall maintain access at all times to manholes, valves, poles, hydrants, panels and other utility controls to utility operators and emergency workers. No material or other obstruction shall be placed within 15 feet of any fire hydrant that is in service. If the Contractor can demonstrate that this requirement is the source of extreme construction hardship, special alternative provisions may be implemented with the approval of the District and the service owner/operator. The Contractor shall not interrupt any service without a minimum of three working days notice to the District and the utility owner, and 2 working days notice to any utility customers affected.

1.3.2.1 Proper Precautions to Avoid Damage to Facilities

The Contractor shall become familiar with all readily available sources of information regarding existing utilities. The Contractor is responsible for verifying the location, size and extents of all utilities shown on plans, marked on site, or otherwise inferred from surface features in order to reduce the possibility of damage during the course of construction.

The Contractor shall comply with Underground Service Alert procedures (USA). The Contractor shall excavate by hand digging when excavating within 24 inches of an existing facility. Markings depicting sub-surface facilities may be up to 24 inches horizontal from outside edge of actual location of facility and still be considered properly marked. Depth information will not necessarily be provided. It is the Contractor's responsibility to carefully locate the utility at whatever depth it exists. The Contractor will not be expected to hand dig through pavement. If a marked facility is not encountered within 24 inches of USA marks, the Contractor should immediately call USA and request re-mark. If the Contractor proceeds with non-hand dig excavation methods prior to re-mark, then any damage inflicted upon the facility, even if miss-marked, is the responsibility of the Contractor.

Sanitary sewer laterals are typically owned by private individuals and will not necessarily be marked or otherwise located. Cleanouts may not exist or be available to help locate sewer laterals. Non-pressurized sanitary sewer and storm drain facilities in general are not required to be located by the regional notification center regulations. Contractor is responsible for all repairs to damaged non-pressurized sanitary sewer facilities and storm drain facilities, regardless of markings, if any.

Abandoned facilities are not required to be located per the regional notification center regulations. If an abandon facility is found, the Contractor should contact the suspected owner or operator of the facility in question to confirm abandonment and safety of the abandoned facility prior to removal. The Contractor shall not make adjustments to the locations or alignments of new facilities without the approval of the Engineer. It shall be the decision of the Engineer whether to re-align the new construction or remove the abandoned facility.

The Contractor shall verify the exact locations of underground facilities by "potholing" sufficiently in advance of sawcutting and excavation operations so that locations and alignments can be confirmed

or re-evaluated without delay. If the Contractor is forced to reconstruct or reinstall materials in order to make minor alterations to alignment, grade, or location due to existing utilities, such minor alterations shall be made at no expense to the District.

1.3.2.2 Repairs to Damaged Facilities

Should the Contractor, disturb, disconnect, or damage any utility facility, the Contractor shall immediately notify the owner or operator of the facility. The owner of the damaged utility shall have the option to have the facility repaired by the Contractor, by a third party contractor of the utility's choice, or to perform the repair itself. If the Contractor is to repair the damaged facility, the repair shall be made within the time frame stipulated by the owner of the facility.

In the case where the facility has been damaged as a result of the Contractor's failure to comply with the notification requirements of the regional notification center (Underground Service Alert or USA), or the requirements of these specifications, and the owner or operator of the facility has complied with the regional notification center requirements, all costs for the repairs to the facility shall be borne by the Contractor. Any claims made against the District by the owner or operator of the facility shall be paid by the Contractor. Such costs may be deducted by the District from any monies due or that will become due to the Contractor under the Contract. No compensation of any kind shall be provided to the Contractor by the District for construction delays due to repairs to damaged facilities. The Contractor shall not base any damage claims or time extension requests upon any delay related to repairs to facilities damaged by the Contractor.

In the case where the owner or operator of the facility has failed to comply with the regional notification center system requirements, that owner or operator shall forfeit any claim for damages to the facility arising from an excavator who has complied with the requirements and to the extent damages were proximately caused by the owner or operator's failure to comply. Claims for damages or delays to construction caused by repairs to damaged facilities shall be made directly with the owner/operator of the facility, and not through SVWD, unless SVWD is the owner/operator.

1.3.3 Saw Cutting and Pavement Removal

Where excavation is located within paved areas, the pavement shall be neatly saw cut and removed. Saw cuts shall be made beyond the limits of excavation, such that an appropriate "tee section" may be constructed conforming to Details 14 or 15, or the requirements of the appropriate public works agency. Saw cutting for trenches outside of the city limits shall conform to the County of Santa Cruz Public Works Figures EP-1, EP-2, and EP-3.

If the saw cut limits are within two feet of edge of pavement, gutter lip or face of curb, the pavement shall be removed completely to that edge.

If saw cut edges become damaged during construction, the Contractor shall make a new saw cut so that edges are neat, vertical and follow straight lines, at no expense to the District.

Where excavation is located within concrete sidewalk, the Contractor shall neatly saw cut the sidewalk only on existing scores. The saw cut limits shall be approved by the Engineer.

1.3.4 Trench Excavation

Excavation of the trench shall follow lines parallel to and equidistant from the pipe centerline. Trenches excavated within city limits shall conform to Details 14 or 15 and these specifications. This includes all pipelines, services and special location trenches that are excavated in conjunction with the project. Trenches outside of the city limits shall conform to the County of Santa Cruz Public Works Trench Backfill Standards, Figures EP-1, EP-2, and EP-3.

Excavations shall be made to depths and widths required to accommodate construction of the pipeline and structures. In general, excavation shall be made to provide the standard depth of cover to finish grade of 36 inches over the top of the pipe. Excavation shall be made to additional depth if indicated by the Contract Documents or required by the Engineer. Prior approval of the Engineer is required if pipe is to be installed with sub-standard cover.

1.3.5 Trench Base Preparation

The trench bottom should be constructed to provide a firm, stable and uniform support for the full length of the pipe. Bell holes should be excavated at each joint to permit proper joint assembly and pipe support. Any part of the trench bottom excavated below grade should be backfilled to grade and should be compacted as required to provide firm pipe support. Where, in the opinion of the Engineer, material encountered at the bottom of the trench is found to be unsatisfactory for properly supporting the pipe, additional trench depth shall be excavated, and refilled with material approved by the Engineer. Where the water main is installed in fill areas, the bottom of the trench shall have been compacted to a minimum of 95% relative compaction before the pipe is installed.

1.3.6 Bell Holes

Bell holes shall be excavated in the bottom of the trench at pipe joint locations of such size that the process of making joints and inspection can be carried on satisfactorily and so that the pipe barrel will bear evenly on the bearing base.

1.3.7 Blasting

No blasting will be permitted without the approval of the Engineer. When blasting is permitted, it shall be done only by skilled operators and under the direction of a competent foreman.

Blasting will be permitted only when proper precautions are taken for the protection of persons, the work and existing structures. Any damage done to persons, private property, the work, or existing structures shall be the responsibility of the Contractor. Storage, handling and the use of explosives shall be in accordance with the State of California (Construction Safety Orders of the Division of Industrial Safety).

Blasting shall be done with explosives of such power and in such quantities and positions as not to make the excavation unduly large, not to shatter the rock upon or against which embankments or concrete will be placed, not to shatter the faces of cuts which are to remain open or not to injure masonry or other structures already built. Whenever, in the opinion of the Engineer, further blasting is liable to injure such rock or masonry, the Contractor shall cease blasting and continue to excavate the rock by other approved methods.

Excessive blasting or "overshooting" will not be permitted and any material outside the authorized cross-section which may be shattered or loosened by blasting shall be removed and replaced with concrete or earth, as specified by the Engineer, at the Contractor's expense. The Engineer shall have authority to require the Contractor to discontinue any method of blasting which leads to overshooting or is dangerous to the public or destructive to property or to natural features.

Permits for blasting shall be obtained and paid for by the Contractor.

1.3.8 Bracing and Shoring

Excavations shall be adequately shored and braced so that the earth will not slide or settle, and so that all existing improvements and facilities will be fully protected from damage. All bracing and shoring shall comply with the State of California Construction Safety Orders of the Division of Industrial Safety, and OSHA excavation standards 29 CFR 1926, Subpart P, Trenching and Excavations. Any damage resulting from lack of or inadequate shoring and bracing shall be the responsibility of the Contractor, and

all costs for repairs shall be borne by the Contractor. Any claims made against the District by the owner or operator of a damaged facility shall be borne by the Contractor. Such costs may be deducted by the District from any monies due or that will become due to the Contractor under the Contract. No compensation of any kind shall be provided to the Contractor by the District for construction delays due to repairs to damaged facilities. The Contractor shall not base any damage claims or time extension requests upon any delay related to repairs to facilities damaged by the Contractor. The Contractor shall bear all other expenses resulting from such damage.

1.3.9 Disposal of Excavated Materials

All excavation spoils and demolished facilities shall be removed from the job site promptly and disposed of at a legal disposal site. No spoils or construction debris may be stockpiled within the Right-Of-Way overnight. Temporary stockpiles of materials shall not obstruct vehicular, pedestrian, or bicyclist traffic. Gutters and catch basins shall be maintained and protected from contamination by construction materials and debris at all times.

The Contractor is responsible for worker health and safety and instructing workers on the recognition and reporting of materials that may be hazardous. The Contractor shall provide and pay for testing and analysis by an approved laboratory of suspected impacted soils and groundwater and shall submit results to the District. Any materials to be removed in the course of work that are found to contain hazardous substances as defined by California Health and Safety Code Section 25117 shall not be transported without prior notification and an approved plan of action. Contractor shall minimize delays by continuing performance of the work in areas not affected by hazardous materials operations.

The Contractor shall be responsible for the proper removal and disposal of asbestos-containing materials when necessary for the installation of new facilities or as called for in the course of work. Contractor shall comply with all current federal, state, and local laws, standards, and regulatory agency requirements concerning the handling of asbestos containing materials. Removal and disposal of existing asbestos materials shall be performed using means and methods as recommended by the American Water Works Association, as allowed by OSHA, and by employees who have been properly trained as required by OSHA. Contractor shall submit a copy of all relevant CAL/OSHA documentation, and documented worker training to District prior to handling any asbestos containing materials. Asbestos disturbance and or removal activities shall be conducted by properly trained, accredited, and licensed personnel using proper protective equipment. Such activity must be performed within a posted regulated area intended to keep unauthorized people out of the asbestos work area. Transite pipe shall be cut only with a snap type cutter and never with an abrasive saw. Field cut transite pipe ends shall not be re-beveled. Asbestos-containing materials must be kept wet and as intact as possible. Such materials must be promptly sealed leak tight in a six mil thick poly bag with labeling that meets OSHA requirements and hauled to a legal disposal facility that accepts asbestos-containing construction debris along with the appropriate waste manifest. The Contractor shall submit a copy of the waste manifest to District in order to document proper disposal

1.4 Installation of DI and PVC Pipe

1.4.1 General

Ductile Iron water mains and water service laterals shall be installed in accordance with AWWA Standard C600, and these specifications. Polyvinyl chloride water mains and water service laterals shall be installed in accordance with AWWA Standard C605, AWWA Manual M23, and these specifications.

1.4.2 Handling of Pipe and Accessories

Proper implements, tools, and facilities satisfactory to the Engineer shall be provided and used by the Contractor for the safe prosecution of the work. All pipe, fittings, and valves shall be carefully lowered into the trench, piece by piece, by means of a crane, straps, slings or other suitable equipment, in such manner as to prevent damage to water main material, protective coating and lining. Under no circumstances shall water main materials be dropped into the trench.

1.4.3 Laying Pipe

1.4.3.1 Cleanliness

Every precaution shall be taken to prevent foreign material from entering the pipe. If the pipe-laying crew cannot put the pipe into the trench and in place without getting earth or water into it, the Engineer may require that before lowering the pipe into the trench, a heavy, tightly woven canvas bag of suitable size shall be placed over each end and left there until the connection is to be made to the adjacent pipe. No debris, tools, clothing or other material shall be placed in the pipe. The contractor shall visually inspect each piece of pipe to verify cleanliness.

At times when pipe-laying is not in progress, the open ends of pipe shall be closed by a water-tight plug or other means approved by the Engineer. If water is in the trench, the seal shall remain in place until the trench is pumped completely dry.

If trench water enters the pipe during construction, or if in the opinion of the Engineer, the pipe has become contaminated, the Special Testing Procedures shall be followed in accordance with the pertinent sections of these specifications.

1.4.3.2 Unsuitable Conditions for Laying Pipe

No pipe shall be laid in water or when, in the opinion of the Engineer, trench conditions are unsuitable. Every precaution shall be taken against floating of the pipe, either in existing lines or in the new lines, due to water entering the trench. In case of such floating, the Contractor shall replace or re-lay the pipe and make good any injury or damage which may have resulted at no expense to the District. All remedial work shall be executed in accordance with the pertinent sections of these specifications.

1.4.3.3 Direction of Laying

Pipe shall be laid with the bell ends facing in the direction of laying, unless directed otherwise by the Engineer.

1.4.3.4 Polyethylene Encasement

When indicated by the Contract Documents, or directed by the Engineer, the Contractor shall install DI pipe and fittings with polyethylene encasement in accordance with AWWA Standard C105, Section

4.4, Method A. Care shall be taken to prevent soil and foreign material from entering the space between the pipe and wrap.

1.4.4 Joints for Pipe and Fittings

1.4.4.1 Cutting Pipe

The cutting of pipe for inserting valves, fittings or closure pieces shall be done in a neat and workmanlike manner without damage to the pipe or cement-mortar lining and so as to leave a smooth end at right angles to the axis of the pipe. The flame cutting of pipe by means of an oxyacetylene torch is prohibited.

1.4.4.2 Cleaning Joint Surfaces

All lumps, blisters and excess coal tar coating shall be removed from the ends of DI pipe. The outside of the spigot and the inside of the bell of DI pipe shall be wire brushed and wiped clean and dry and free from oil and grease before the joint connection is made.

The outside of the spigot and the inside of the bell of PVC pipe shall be wiped clean and dry and free from oil and grease before the joint is made.

1.4.4.3 Permissible Deflection at Joints

Wherever it is necessary to deflect pipe from a straight line, either in the vertical or horizontal plane, to avoid obstruction or to plumb stems, or where long-radius curves are permitted, the deflection shall not exceed the manufacturer's recommendation. Bends shall be used whenever individual deflections exceed those specified by the manufacturer.

1.4.4.4 Joint Types

Joints between lengths of DI pipe shall be push-on rubber ring, or mechanical joint. Joints between lengths of PVC pipe shall be push-on rubber ring. Other joint types shall be approved by the Engineer.

All pipe joints shall be installed in accordance with the pipe manufacturer's instructions.

The pipe shall be marked a known distance from the end of the spigot, so that spigot embedment in the joint may be verified. Pipe spigots shall be evenly beveled and thoroughly de-burred. Pipe joint surfaces shall be wiped clean and gasket lubricant applied immediately prior to joint assembly to prevent dirt from becoming lodged in the gasket.

All uncoated areas of fittings and joint related hardware shall be completely covered in bitumastic coating by either brush or spray application to protect against corrosion.

1.4.4.5 Restrained Joints

Pipe joints shall be restrained at all fittings, valves, and where required by the Engineer. In addition to the fitting joints themselves, a length of pipe, as measured along the pipe from the fitting, shall be restrained. The restrained length shall be determined from Detail 18, or specified by the Engineer.

All joint restraint hardware shall be installed in accordance with the manufacturer's instructions. Bolts shall be tightened to the manufacturer-recommended torque. A torque wrench shall be used to tighten pipe-gripping joint restraints if the factory-provided break-away bolt heads are missing.

All uncoated joint restraint related hardware shall be completely covered in bitumastic coating by either brush or spray application to protect against corrosion.

In addition to restraining joints as described above, the Contractor shall install thrust blocks or reverse anchors in accordance with the pertinent sections of these specifications and Detail 19.

1.4.5 Miscellaneous

The Contractor shall install test stations, insulating fittings, joint bonds and other cathodic protection facilities as indicated by the Contract documents, or the Engineer.

1.5 Installation of Steel Pipe

1.5.1 General

Installation of steel pipe shall be installed per AWWA Standard C604 and AWWA Manual M11.

1.5.2 Handling of Pipe

Whenever a section of lined and coated or wrapped steel pipe is to be lifted or moved, it shall be handled in such a manner as not to distort the pipe excessively and/or damage the lining, coating, or wrapping in any way.

Belt slings shall be used whenever coated pipe is to be lifted. The belt shall be so constructed that no metal bears against the pipe coating.

1.5.3 Laying Pipe

The pipe shall be accurately laid to grades and alignments indicated by the Contract Documents. It is the intent of this specification that the pipe be installed as prefabricated in the shop by the manufacturer. If a discrepancy is discovered during installation between field conditions and the Contract Documents, the first attempt at conformity shall be to re-grade the area in question before the pipe is altered in the field to meet ground conditions. In any case, the decision of the Engineer shall be final.

Pipe sections shall be thoroughly cleaned just prior to being placed in position. Pipe installed in the trench shall have uniform support along the base, except at bell holes provided for field joints or other structures.

Pipe shall be laid and joined in accordance with instructions of the pipe manufacturer. Joint deflections shall not exceed the maximum recommended by the manufacturer.

If trench water enters the pipe during construction, or if in the opinion of the Engineer, the pipe has become excessively contaminated, The Special Testing Procedures described in these specifications shall be followed.

1.5.4 Field Joints

Field joints may be lap welded, flanged, flexible coupled or of the rubber gasket bell and spigot type. Flanged joints shall be fitted with ring gaskets.

The jointing operation for bell and spigot pipe shall provide for the use of a feeler gauge to check the position of the rubber gasket for proper seating. If pipe is specified as cement mortar lined, all joints shall be finished inside with cement mortar after final placement.

After joints in wrapped or coated pipe have been inspected, exterior wrapping or coating shall be applied to the joints so as to produce a protective covering equal to that of the manufactured pipe.

1.5.5 Field Alterations and System Connections

Whenever the pipe is cut for the purpose of making alterations or closures, the coating shall be cleaned back from the line of cut approximately 3 inches, and the pipe shell accurately cut.

All field-fabricated elbows shall be in accordance with AWWA Standard C208, Table 2.

1.5.6 Welding

Welding of steel pipe shall conform to the Standard Specification of the American Water Works Association for Field Welding of Steel Water Pipe Joints and designated as AWWA Standard C206, and shall be done by a certified welder.

1.5.7 Miscellaneous

The Contractor shall install test stations, insulating fittings, joint bonds and other cathodic protection facilities as indicated by the Contract Documents.

1.6 Installation of Appurtenances

1.6.1 Hot Tap Connections

In the locations indicated by the Contract Documents or the Engineer, the Contractor shall install a hot tap connection in accordance with these specifications, Detail 1, and AWWA C600 or C605. No hot tap connections shall be made without the presence of the Engineer. The Contractor shall schedule inspection with SVWD a minimum of two working days in advance of making any hot tap connection.

1.6.1.1 Tap Location

The Contractor shall expose the main for 24 inches on either side of the proposed tap location to confirm that no other taps, bells, or other fittings exist near the new tap. No taps shall be made within 18 inches of another tap, nor 24 inches from any fitting, bell, or other joint. Multiple taps in the same stick of pipe shall be staggered around the circumference of the pipe.

1.6.1.2 Tap Installation

The Contractor shall clean the main and install the appropriate tapping saddle or sleeve. Direct taps are prohibited. The bit used to drill into the main shall be a hole-saw or shell bit unless approved otherwise by the Engineer. For services smaller than 4 inches, the diameter of the bit shall not be smaller than one eighth of an inch less than the size of the service. For services 4 inches and larger, the diameter of the bit shall not be less than one quarter of an inch less than the size of the service. The bit shall be equipped with a coupon-retention mechanism, such as a barbed pilot bit.

1.6.1.3 Use of Purge Valve

During the tapping operation, the Contractor shall maintain positive flow of water out of the main, such that cuttings are continuously flushed out. This may be achieved by opening the purge valve on the tapping equipment or tapping saddle or sleeve. If the tapping equipment does not have an integral purge valve, the Contractor shall install a temporary tee between the corporation stop and the tapping machine, and attach the purge valve to the tee.

1.6.1.4 Polyethylene Encasement

When a hot tap connection which utilizes brass and copper, is made to an iron or steel main, the brass tapping saddle shall be completely covered in bitumastic coating by either brush or spray application. The main, saddle and service line shall be encased in polyethylene wrap for a minimum distance of 3 feet from the hot tap connection.

When a hot tap connection is made to a main which is encased in polyethylene, the polyethylene shall be neatly cut back out of the way of tapping operations, and protected from damage. In accordance with AWWA C105, the finished hot tap connection, associated hardware and service line shall be encased in polyethylene wrap for a minimum of 3 feet along the service lateral from the encased pipe.

1.6.2 Installation of Copper Pipe

1.6.2.1 Laying

In laying the copper tubing the Contractor shall ensure that the tubing is not subject to point loads due to any source, kinking or crimping, cuts, scratches, or abrasions in excess of 10 percent of the tubing wall thickness. All tubing shall be cut using a cutter designed for cutting copper tubing. Damaged

tubing shall be removed and replaced in accordance with the provisions of these Standard Specifications.

1.6.2.2 Curves and Bends

In approaching and leaving fittings and meters, the tubing shall not be bent in a curve with a radius tighter than 30 times the nominal diameter of the tubing. A straight run of tubing at least 10 times the nominal diameter shall be provided on each side of each fitting. A tubing bender shall be used to prevent crimping of the copper tubing.

1.6.2.3 Damage

Any damage to the tubing or fitting including but not limited to evidence of over tightening, misaligned threads, burring or scarring of machined faces, or any evidence of leakage shall be cause for rejection. If a leak is found to be caused by debris, the debris shall be cleared and the tubing and fitting visually inspected for damage before being charged. If the leak recurs upon charging of the line, the tubing and fitting shall be removed and replaced whether or not the cause can be determined.

1.6.2.4 Minimum Length

When the total continuous length of tubing is less than 3-feet, the entire length shall be removed and replaced. When the total length of copper tubing exceeds 3-feet, the damaged fitting shall be removed along with the preceding 6-inches (minimum) and replaced with a brass Grip Tite[®] pack joint, or compression type coupling and replacement fitting and a length of Type "K" copper tubing.

1.6.2.5 Dissimilar Connection

Where a copper tubing is to be connected to a dissimilar metal, a dielectric union shall be used to isolate the materials and prevent corrosion.

1.6.3 Installation of Valves

The Contractor shall install valves at the locations indicated by the Contract Documents or where directed by the Engineer. Valves shall not be located in concrete sidewalks, aprons or gutters, unless approved by the Engineer. On mains smaller than 12 inches in diameter, the spacing between valves shall not exceed 500 feet. Four valves shall be installed at each cross. At least one valve shall be installed at each tee on the leg branching from the tee. Valves shall be installed directly on the cross or tee, unless directed otherwise by the Engineer.

Installation of valves shall conform to Detail 11 and these specifications. For all valve installations where the top of valve nut is more than four feet below the ground surface, a valve nut extension shall be installed so that the operating nut is within 12 inches of the ground surface. Valve nut extension stems shall have a rust-inhibitive coating and be equipped with a circular spacer to ensure that the stem extension stays centered within the valve box.

Joints between valves and pipe or other fittings shall be restrained in accordance with the pertinent sections of these specifications for the applicable pipe type. Joints in pipe adjacent to valves shall be restrained in accordance with the pertinent sections of these specifications and Detail 18.

Uncoated joint hardware, and areas on the valve body where coating has been damaged shall be completely covered in bitumastic coating by brush or spray on application to prevent corrosion.

The Contractor shall note that only SVWD Personnel are authorized to operate valves on the existing system. The Contractor may operate valves on new construction that has not been connected to the existing SVWD water system.

1.6.3.1 Valve Box Installation

A valve box and lid shall be installed over operating nuts per Detail 11. If valve boxes are exposed above the ground surface, they shall be protected from damage until completion and acceptance of the contract work.

Valves boxes shall be installed flush with finished grade and centered on the valve nut, such that the centerline of the riser is aligned with the axis of the operating nut. Valve boxes and risers which have shifted during backfill operations and are no longer aligned in this manner shall be re-excavated and realigned to the satisfaction of the Engineer.

Valve box lids shall be marked in accordance with Detail 12.

Valve boxes and lids shall be inspected by the contractor prior to installation to ensure that the lid is silent when driven over by vehicles. Noisy gate valve boxes and/or lids shall be removed and replaced at no expense to the District, or shall be remedied in a manner acceptable to the Engineer.

1.6.3.2 Valve Box Adjustment

Valve box rims shall be adjusted to be flush with the finished grade whenever paving is overlain or existing grades are changed. Adjustment shall be made by removing paving, concrete collar or redwood blocks, and affected backfill. Valve boxes with existing concrete collars shall be replaced with a new valve box. A new concrete collar shall be poured around the box per Detail 11. Pavement or landscaping surrounding valve box shall be replaced in-kind. Use of grade rings is prohibited.

Damaged lids shall be replaced. Valve box lids shall be marked in accordance with Detail 12. Replacement lids shall be inspected by the contractor to ensure that the lid is silent when driven over by vehicles. Noisy gate valve boxes and/or lids shall be removed and replaced at no expense to the District, or shall be remedied in a manner acceptable to the Engineer.

1.6.4 Installation of Blow-Offs

Where indicated by the Contract Documents or designated by the Engineer, the Contractor shall install either a temporary or permanent blow-off. A permanent blow-off is defined as one that will be left in place upon completion of the work. Permanent blow offs shall conform to Detail 23 and these specifications. Temporary blow-offs shall be removed by the Contractor after testing has been completed and approved by the Engineer. The Contractor shall execute all work related to the installation and removal of blow-offs in accordance with the pertinent sections of these specifications. Unless otherwise specified by the Engineer, the size of blow-offs shall be 2 inches. Blow-offs shall be installed on mains at low points, dead-ends and disinfection locations.

1.6.5 Air Valve Installation

The Contractor shall install an air valve in accordance with these specifications and Detail 24 at locations indicated by the Contract Documents or where required by the Engineer. Air valves are required at each high point in all transmission water mains 12 inches in diameter and larger, as directed on the Contract Documents , or at the direction of the Engineer. Air release valves shall be located so that the vent opening is above the 100-year flood level or the highest recorded water level, whichever is higher.

If indicated by the Contract Documents or the Engineer, the Air valve shall be installed in a below grade configuration per Detail 25. Air valves may be installed in below grade configuration only with prior approval of the Engineer.

In locations where vehicular damage of the air valve is a concern, the Engineer may require that the Contractor install bollards per Detail 20. In locations where vandalism of the air valve is a concern, the

Engineer may require that the Contractor install a locking steel enclosure. The enclosure shall be installed upon a reinforced concrete pad and shall be painted with "hunter green" enamel

1.6.6 Fire Hydrants

Fire hydrants are allowed for public fire protection purposes only. Private hydrants may be located on private property but shall be connected to a standard fire service with an approved backflow prevention device. Adequate water main size and point of connection shall be verified prior to installation. Water main replacement or extension may be required to provide adequate pressure and flows. The Contractor shall schedule the work a minimum of 2 working days prior to construction. Out of service hydrants shall be bagged with a canvas or orange bag. The Engineer shall notify the local fire agency when hydrants are turned on or off.

1.6.6.1 Fire Hydrant Location Requirements

Fire hydrant locations shall be approved by the Engineer and Fire District prior to installation. The installer/developer shall notify the owners of all properties within 250 feet of the proposed hydrant location in writing a minimum of five working days before the hydrant is installed.

Fire hydrants shall connect only to water mains 6 inches and larger in diameter. If the water main is less than 6 inches in diameter, the main shall be upsized.

See Appendix 1, Hydrant Installation Permit Requirements.

No fire hydrant shall be located within 10 feet of a driveway approach. No fire hydrant shall be located within 3 feet of private property lines.

No fire hydrant shall be located within 3 feet of walls, poles, or any other vertical obstructions. No fire hydrant shall be located below power lines. No fire hydrant shall be located within 4 feet of a mature shrub. Consideration shall be given to proximity of young shrubs. No fire hydrant shall be located within the drip line of existing mature trees. Consideration shall be given to the proximity of young trees.

The hydrant lateral length shall be minimized by locating the hydrant on the short side of the water main. Excess fittings shall be eliminated by using full lengths of pipe. Bends in the lateral are prohibited, subject to the discretion of the Engineer.

The hydrant location shall be selected to minimize impacts on neighborhood parking and aesthetics. Hydrants located mid-block shall be placed to straddle extended property lines, so that the hydrant is not located directly in front of one parcel.

If an easement is required for the hydrant location and clearances, the applicant shall prepare the easement using the District's format and language and obtain any necessary survey information. The District shall review and approve the easement before it is finalized.

1.6.6.2 Fire Hydrant Installation

The Contractor shall install a new fire hydrant where indicated by the Contract Documents or the Engineer. Fire hydrants shall be installed per Detail 10, and these specifications.

The fire hydrant shall connect to the water main via 6-inch diameter lateral pipe. The lateral piping shall consist of DI or PVC pipe installed in accordance with the pertinent sections of these specifications. Every joint on the lateral shall be restrained. The hydrant lateral trench shall be constructed in accordance with Detail 14. The minimum depth of cover is 36 inches. The Contractor

shall install a thrust block per Detail 19 at the base of the hydrant bury and behind the tee or tapping sleeve used to connect to the water main.

The hydrant and hydrant bury shall be installed plumb. The hydrant bury shall be properly sized such that the flange face is 2-4 inches above finished grade, and adequate clearance is provided for flange bolts. Flange bolts shall be installed with the bolt shaft pointing down.

Fire hydrants shall be installed with the large 4.5-inch diameter outlet facing the street. Outlet cap chains shall be removed. Fire hydrants shall be painted with "post international yellow" enamel.

Where a hydrant is to be installed outside of concrete sidewalk, the hydrant shall be centered in a 6-inch thick, 4 foot by 4 foot reinforced concrete pad constructed in accordance with the pertinent sections of these specifications and Detail 10.

Where required by the Engineer or the Fire District, the Contractor shall install traffic bollards per Detail 20 and the pertinent section of these specifications.

All related work such as saw cutting, trenching, hot tapping, backfill and paving shall be executed in accordance with the pertinent sections of these specifications.

1.6.6.3 Fire Hydrant Relocation

When indicated by the Contract Documents or the Engineer, the Contractor shall relocate a fire hydrant. The Contractor shall remove the existing hydrant and hydrant lateral, and install a new hydrant in accordance with all pertinent sections of these specifications. All new parts shall be used in the installation of said fire hydrant, unless approved otherwise by the Engineer.

1.6.7 Flexible Couplings and Repair Clamps

With the approval of the Engineer, connections to existing water mains may be made with flexible couplings when the existing main is made of material which will not allow a restrained joint. Such couplings shall be installed in accordance with the manufacturer's recommendations. Care shall be taken to ensure that the pipes are in proper alignment and that smooth surfaces have been provided so that the couplings can be properly fitted. Attention shall be paid to the fact that flexible couplings are not restrained joints. Care shall be taken to not interrupt the required restrained length of an existing pipe in the act of repairing it.

Broken or leaking water mains may be repaired with stainless steel repair clamps. Such clamps shall be installed in accordance with the manufacturer's recommendations and the discretion of the Engineer.

All uncoated areas of flexible couplings, repair clamps, and any non-stainless steel hardware shall be completely covered in bitumastic coating by either brush or spray application to protect against corrosion.

1.6.8 Water Services

When indicated by the Project Documents or the Engineer, the Contractor shall install a complete service line in accordance with these specifications and applicable Details. A water service shall consist of a hot tap connection to the main, lateral piping, installation of a meter box, all meter-related fittings and pipe, and a backflow prevention assembly where required in accordance with SVWD Backflow Protection Policy. All related work such as excavation, pavement removal and replacement shall be executed in accordance with the pertinent sections of these specifications.

Water services 2 inches and smaller in diameter shall be installed per Detail 5. Water services 3 inches or 4 inches in diameter shall be installed per Detail 6. Water services 6 inches and larger in diameter shall be installed per Detail 7.

Services may be combined in certain instances with the approval of the Engineer. Combination fire and domestic services for single family dwellings shall be installed per Detail 4. Multiple 1-inch and smaller domestic and irrigation services may be combined per Detail 3.

All water meters, regardless of size, connected to the SVWD system shall be purchased by and remain property of SVWD. Under no circumstances shall anyone other than SVWD personnel remove a water meter once the service has been inspected and approved, unless otherwise directed by SVWD personnel. Customer-owned sub meters are allowed, if located on the customer's side of the District owned meter.

1.6.8.1 Service Lateral Installation

The Contractor shall make a hot tap connection in accordance with the pertinent sections of these specifications and Detail 1. No service taps shall be made within 18 inches of another service tap, nor within 24 inches of any fitting, bell, or other pipe joint. With the approval of the Engineer, the location of the tap may be offset up to 8 feet horizontally from the meter box location to avoid such obstacles.

The Contractor shall install a service line of size, material and in the alignment indicated by the Contract Documents or the Engineer. Service lines may be laid in an open cut trench or placed through a hole produced by a horizontal jacking or drilling tool. The Contractor shall minimize the number of joints in service lines by using full lengths of pipe.

Service lateral trenches shall be constructed in accordance Detail 14. The minimum cover for services smaller than 6 inches in diameter is 24 inches. The minimum cover for services 6 inches in diameter and larger is 36 inches.

Five feet clear horizontal distance shall be maintained between water service laterals and sanitary sewer laterals. Three feet clear distance shall be maintained between water service laterals and other utility lines. If there is no alternative but to install a sanitary sewer lateral within the minimum clear distance, the Engineer may allow the installation if the sanitary sewer lateral is encased in concrete. Water service laterals shall not be constructed in joint trenches with any other utility.

1.6.8.2 Disinfection

Service laterals shall be disinfected if required by the Engineer. Disinfection and testing shall be executed in a manner approved in advance by the Engineer.

1.6.8.3 Meter Box Installation

The Contractor shall install meter boxes in the locations indicated by the contract documents or the Engineer. Meter boxes shall be installed in accordance with Detail 2 and these specifications.

All District-owned meter boxes shall be located within City or County Right-of-Way or in utility easement allowing installation and maintenance of water mains, laterals, appurtenances and water meters. If an easement is required, the applicant shall prepare the easement using the District's format and language and obtain any necessary survey information. The District shall review and approve the easement before it is finalized.

1.6.8.4 Radio Read Conduit

Where water meters are installed within 10 feet of other new or existing water meters, the Contractor shall install a conduit between said meter boxes per Detail 2 and these specifications. The ends of the conduit shall rise a minimum of 3 inches above the soil in the meter box. The Contractor shall

place tape over the ends of the conduit to prevent soil from entering the conduit. All electronics and wiring shall be installed by District forces.

1.6.8.5 Meter Box Relocation or Service Retrofit

Where indicated by the Contract Documents or the Engineer, the Contractor shall relocate and/or retrofit a service.

Meter boxes may be offset from the standard location (which is perpendicular to the main), up to 8 feet along the public road right of way. If a meter box must be relocated further than 8 feet from its original location, the service lateral shall be removed and a new service installed in accordance with pertinent sections of these specifications.

The Contractor shall schedule a service line shut down with SVWD a minimum of two working days in advance of the proposed relocation or retrofit. The Contractor shall expose the valve or corporation stop for SVWD personnel to operate. Only SVWD personnel may operate valves or corporation stops. Pipe freezing as a means of temporary shutdown of a service may be allowed at the discretion of the Engineer. In no instance shall service pipe be crimped.

The Contractor shall remove the old meter box, related fittings and lateral piping, and install a new meter box, related fittings and lateral piping in accordance with the pertinent sections of these specifications. The new service shall fully conform to the latest version of these specifications. The extents of lateral piping to be replaced shall be determined solely by the Engineer. All related work such as backfill, paving and site restoration shall be executed in accordance with the pertinent sections of these specifications, and the specifications of the applicable public works agency.

1.6.9 Installation of Backflow Prevention Assemblies

The Contractor shall install a backflow prevention assembly in the location indicated by the Contract Documents or the Engineer. Backflow prevention assemblies shall be installed in accordance with SVWD Backflow Protection Policy, the pertinent SVWD Detail(s), and the pertinent sections of these specifications. Backflow prevention assemblies shall remain the property and responsibility of the parcel owner.

Following acceptance of the installation, the assembly shall be performance tested on an annual basis at the owner's expense by a certified tester selected from the SVWD approved list.

1.6.9.1 Location

The backflow prevention assembly shall be located immediately after the meter to which it is attached, with no room available for a cross connection. If the meter is integral with the assembly, the assembly shall be located within 8 feet of the right-of-way boundary. The assembly shall be installed such that the device is readily accessible for testing and maintenance. The location of all assemblies shall be approved by the Engineer prior to installation.

1.6.9.2 Assemblies

Backflow prevention assemblies shall be greater than or equal to the diameter of the service designated by the Engineer. Two or more backflow prevention assemblies may be installed in parallel if a continuous water supply is desired during testing and repairs. In this case, the sum of the cross-sectional areas of the assemblies shall be at least equal to the cross-sectional area of the service connection.

1.6.9.3 Protective Cover or Cage

If the assembly is installed where vandalism or damage due to freezing may be a problem, the unit may be protected and secured at owner's expense. Handles of valves may be removed to discourage tampering. Alternatively, a protective cage or cover can be installed over the unit.

In cases where the water meter is to be installed above-ground, integrated with the backflow prevention assembly, the water meter shall be protected with a locking enclosure approved in advance by the Engineer.

Cages shall be installed so that adequate clearance is available for maintenance and testing or that the cage is completely removable. The Contractor shall allow for any discharge from the relief valve to fully drain from the protective cage or cover.

1.6.10 Pipe Location Wire

The installation of non-metallic water main shall include a coated, stranded ten gauge copper wire taped directly on the pipe per Detail 15 and these specifications.

The wire shall be taped to the top of the pipe using duct tape at intervals not exceeding 10 feet. The interval may be decreased by the Engineer to ensure that the wire remains securely in place during backfill operations.

The copper wire shall be continuous. If continuity is not possible, the Engineer may allow wire to be spliced by soldering. Soldered joints shall be made in a workmanlike manner to ensure long term mechanical strength and electrical continuity. The wire shall be heated, flux applied, and the solder shall be melted by the hot wire, such that the solder flows readily into the wire strands. The joint shall not be moved until it has cooled. Joints that are cloudy in appearance shall be reheated so that they are shiny. The soldered joint shall be wrapped in vinyl electricians tape or heat-shrink tubing.

Where indicated by the Contract Documents or the Engineer approved wire connectors may be used.

Pipe location wire shall be brought up on the outside of all valve box riser pipes, and held in place inside the valve box by wedging it securely between the valve box and the riser pipe or in a vertical slot cut in the top of the riser pipe per Detail 11. Pipe locating wires shall not be installed in contact with metal valve key extensions or other metal pipes or appurtenances.

1.6.11 Chlorination Tap

Where indicated by the Contract Documents or the Engineer, the Contractor shall install a chlorination tap per Detail 22, and these specifications. The chlorination tap shall be centered in the meter box. Chlorination taps shall not be located further than 10 feet downstream of the beginning of the section to be chlorinated.

1.6.12 Pressure Regulating Station

The Contractor shall install pressure regulating stations at the locations indicated by the Contract Documents or where directed by the Engineer. In saturated ground, the pressure regulating station vault shall be located in a shed of design approved by the Engineer. Pressure regulating stations installed below ground shall include a drain from the vault. The station vault shall be easily accessible with ladder rungs mounted in vaults deeper than 3 feet. The station shall have an H/20 load rating, vaulted, padlock-capable aluminum lid with a gooseneck type screened vent. All exposed pipe and fittings shall be painted with non-VOC epoxy paint or with 2 coats of rust preventative enamel.

1.6.13 Sample Station

The Contractor shall install sample stations at the locations indicated by the Contract Documents or where directed by the Engineer. The stations shall be installed as indicated on Detail 21. The station shall be easily accessible. All exposed pipe and fittings shall be painted with "hunter green" non-VOC epoxy paint or with 2 coats of rust preventative "hunter green" enamel.

1.6.14 Appurtenant Concrete Work

The Contractor shall install plain and reinforced concrete required for construction of appurtenances where indicated by the Contract Documents, or the Engineer. Concrete work shall conform to current applicable ACI standards. Concrete for thrust blocks, reverse anchors, post embedment, and concrete collars may be hand mixed on site.

The ground against which concrete is to be placed shall be moistened previous to placement so that it will not absorb excessive moisture from the green concrete. Forms required shall be smooth, mortar tight and of sufficient strength to maintain shape during the placement of the concrete. Placement methods shall be such that the concrete will be placed in its final position without segregation. All concrete shall be rodded and spaded to ensure smooth surfaces along form lines and to eliminate rock and air pockets. The use of mechanical vibrators is not required on anchors and valve supports.

Concrete shall not be placed in free water. Pumping from the interior of any foundation enclosure shall be done in such a manner as to prevent the concrete from being carried away. No pumping will be permitted during the placing of concrete, or for a period of 24 hours thereafter, unless it is done from a suitable sump separated from the concrete. Water shall not be allowed to rise on any concrete until the concrete has attained its initial set.

1.6.14.1 Thrust Blocks and Reverse Anchors

The Contractor shall install thrust blocks at all fittings where indicated by the Contract Documents or where required by the Engineer. Thrust blocks on fittings 10 inches in diameter and smaller shall be installed per Detail 19. Thrust blocking on fittings larger than 10 inches in diameter, at depths less than 36 inches, or in poor soils shall be designed on a case-by-case basis. Designs shall be approved by the Engineer prior to construction.

1.6.14.2 Fire Hydrant and Backflow Prevention Device Concrete Pads

Where a fire hydrant is to be installed outside of paved sidewalk area, or when required by the Engineer, the Contractor shall install a reinforced concrete pad per Detail 10. Backflow prevention devices shall be installed in a reinforced concrete pad in accordance with the applicable SVWD Detail.

Concrete pads required for fire hydrant installations shall be reinforced. Reinforcing steel shall consist of #3 rebar placed at 12 inches on center, each way, or welded steel wire mesh of equivalent cross sectional area. Reinforcing steel shall be centered vertically in the concrete. Three inches minimum clearance shall be maintained between the edge of the concrete and reinforcing steel on all sides. Concrete pads shall be sloped away from the hydrant bury such that water is prevented from ponding adjacent to the pipe.

Reinforcement of Concrete pads for backflow prevention devices shall be installed as specified above for fire hydrant pads or as indicated by the Contract Documents.

1.6.15 Traffic Bollard Installation

Where indicated by the Contract Documents or the Engineer, the Contractor shall install a traffic bollard per Detail 20, and these specifications.

Traffic bollards shall be installed plumb and shall be four feet tall unless otherwise directed by the Engineer. The concrete foundation or paving at the base of the bollard shall be sloped away from the steel pipe such that water is prevented from ponding adjacent to the pipe. The traffic bollard shall be painted with "post international yellow" enamel unless it is protecting a private fire hydrant or backflow device, in which case it may be painted to match the device. Traffic bollards shall have a 6-inch tall reflective strip placed near the top of the bollard after it is painted.

1.7 Backfill and Paving

1.7.1 General

Before backfilling, the trench shall be cleared of all debris and deleterious material such as wood blocks, grade stakes, paper, rope, rags, rocks and pavement chunks. Care shall be taken to ensure that the material used for backfilling is free from such debris.

Following completion and acceptance of the backfill, the area shall be paved in accordance with these specifications and Details 14 or 15 as soon as possible.

Unless otherwise approved by the Engineer, no more than 50 feet of trench shall be open and plated at the end of each work day.

1.7.2 Backfill

Trenches within the City limits shall be backfilled in accordance with these specifications and Details 14 or 15. Backfill of trenches outside of the City limits shall conform to the County of Santa Cruz Public Works Trench Backfill Standards, Figures EP-1, EP-2, and EP-3. This requirement applies to all pipelines, services and other excavations in conjunction with the project.

The Contractor shall in general, install pipe at the standard depth of 36 inches. Where there is no reasonable alternative but to install water main or water services 6 inches and larger with less than 36 inches of cover, a 12-inch thick concrete cap shall be constructed in place of standard backfill, and class 350 or better DI pipe shall be installed per Detail 16. Prior approval of the Engineer is required to install pipe in this manner.

Backfill material shall not be placed over or around any fitting, thrust block, restrained joint, or cathodic protection system component until the object has been inspected and approved by the Engineer. After completion of the installation of the pipe and appurtenances to the satisfaction of the Engineer, the remainder of the trench shall be backfilled.

During the process of backfilling, any timbering, sheeting, shoring or sheet piling used to shore the excavation shall be carefully removed in such a manner as will result in a minimum of caving, lateral movement or flowing of the soil.

1.7.2.1 Backfill Placement

Unless approved otherwise by the Engineer, the Contractor shall place and tamp a sand bedding prior to laying pipe in accordance with Details 14 or 15.

The sand backfill immediately surrounding the pipe (pipe-zone) shall be brought up evenly on each side of the pipe and thoroughly tamped in place. Installation of PVC pipe requires that the material from the bottom of the pipe to the spring line of the pipe (haunching) be hand-tamped to the satisfaction of the Engineer. Pipe-zone sand backfill shall cover the pipe by the depth indicated by the appropriate Detail or the Engineer. Pipe-zone sand shall be moisture conditioned and uniformly compacted to 90% relative compaction.

The remaining portion of the backfill extending from the top of the sand to the underside of the paving (trench zone) shall consist of aggregate base. Trench-zone aggregate base shall be moisture conditioned and uniformly compacted to 95% relative compaction.

Trench-zone backfill for service laterals shall be controlled low strength material (CLSM) unless approved otherwise in advance by the Engineer.

With approval of the Engineer, tunneling for short distances under existing facilities, sidewalks and pavement may be allowed. Tunneled sections shall be backfilled with CLSM.

The final lift of backfill material in trenches through unpaved areas shall consist of topsoil similar to that removed, or other material approved by the Engineer, compacted to 90% relative compaction.

1.7.2.2 Compaction Methods

The Contractor shall compact backfill by mechanical means, using equipment approved by the Engineer. The maximum loose-placed lift thickness shall be as determined by the Engineer, based on the type of compaction equipment used, and the observed quality of the work. Native soils may not be free draining, thus hydraulic compaction methods are prohibited.

1.7.2.3 Compaction Testing

The Contractor shall verify the compaction of all backfill material installed. The number of tests required shall be determined by the length of the trench divided by 50 feet. However, the intervals between compaction tests, and the locations of the tests shall be as determined by the Engineer.

The Contractor shall provide the name, contact information and provide the qualifications of an independent Geotechnical Engineering Firm who is routinely engaged and fully qualified to conduct the confirmation tests specified. The laboratory shall be approved in writing by the Engineer prior to the start of any backfill operations. All costs of materials and confirmation testing shall be borne by the Contractor.

The maximum dry density of each type of backfill material shall be submitted to the Engineer as part of the materials submittal. Copies of the field test reports shall be submitted to the Engineer prior to paving, upon request of the Engineer, or upon acceptance of the work.

If indicated by the Contract Documents or the Engineer, the District will retain the services of a geotechnical engineering firm, and coordinate all compaction testing. In this case, the Contractor will not be relieved of the duty of providing work which complies with these specifications. The Contractor shall coordinate their work schedule with the Engineer such that the work is accessible to the District's compaction tester. No compensation will be provided to the Contractor for construction delays due to compaction testing. The Contractor shall not base any damage claims or time extension requests upon delay related to compaction testing. No compensation will be provided to the Contractor for work or materials that must be removed and replaced to provide proof of compliance with these specifications.

If any compaction test reveals sub-standard compaction, or if the Engineer observes evidence of sub-standard compaction, the Contractor shall replace and/or re-work the backfill material within the limits designated by the Engineer. The re-worked area shall be re-tested in the location(s) designated by the Engineer. All remedial work shall be done at no cost to the District.

1.7.3 Paving

Following the Engineer's acceptance of the backfill, roadway and/or sidewalk paving shall be replaced in kind wherever it has been removed. Paving which has been damaged by operations of the contractor shall be replaced in kind per these specifications at no expense to the District. The materials and methods used for paving shall conform to the specifications of the appropriate public works agency and shall be approved by the Engineer. The final surface attained shall be subject to the approval of the Engineer.

Permanent surfacing material shall be placed on the base as soon as possible after backfilling is accepted. Prior to replacing the pavement, the edges of the existing pavement shall be neatly saw cut to

a vertical plane and in straight lines. If the existing pavement was previously saw cut and the condition of edges has deteriorated, the Contractor shall saw cut new edges at no expense to the District. The edges shall be thoroughly cleaned of all mud, dirt and dust before placing the surface material.

All traffic striping (centerlines, fog lines, lettering, etc.) shall be replaced in-kind. Thermoplastic striping shall be applied if required by the Engineer.

1.7.3.1 Asphalt Concrete Paving

The roadway surfacing shall be replaced to a depth equal to the existing depth, but not less than 3 inches.

The edges of the existing pavement shall be completely coated with an asphaltic emulsion by spraying. Brushes or daubers shall not be used.

Proper asphalt temperature shall be maintained during paving operations. Hot mix asphalt shall come off the truck at a temperature greater than 275 degrees Fahrenheit. Spread and breakdown of the asphalt shall be completed before the asphalt cools below 200 degrees Fahrenheit. The paving shall be finished before the asphalt cools below 150 degrees Fahrenheit. Asphalt shall not be placed if the temperature of existing pavement adjacent to the area to be paved is less than 50 degrees Fahrenheit.

The completed surfacing shall be thoroughly compacted by power roller and shall be free from ruts, bumps, depressions or irregularities. A seal coat shall be applied if required to match the surface texture of the existing pavement. The final pavement surface shall transition smoothly to the existing pavement.

The Contractor shall fill all saw cuts with sand and seal with an asphalt crack sealant approved by the Engineer.

If there will be a delay in final paving, a temporary 1-inch thick asphaltic plant mix surface shall be placed immediately after backfilling has been completed and removed just prior to placing the permanent surfacing material. Until the permanent surfacing material is placed, the base rock or temporary asphaltic plant mix at the surface of the trench shall be maintained at all times at a grade level with the adjacent street.

1.7.3.2 Portland Cement Concrete Paving

The edges of the existing pavement and the surface of the base material shall be thoroughly wetted just prior to placing new concrete.

Concrete paving shall be 6 inches minimum thickness unless specified otherwise by the Engineer. Concrete shall be placed to match all existing expansion joints and deep scores. Concrete shall be edged with a ¼ inch chamfer. Concrete paving shall be reinforced with #4 rebar dowels placed at 24 inches on center, each way. Reinforcing steel shall be centered vertically in the pavement section. Reinforcing steel shall be embedded a minimum of 6 inches into adjacent portland cement concrete paving. Concrete certification tickets shall be submitted to the Engineer.

1.8 Removal and Abandonment

1.8.1 Valves

Valves appurtenant to water mains which are to remain in service shall be removed in accordance with these specifications when no longer needed. In-place abandonment of valves attached to mains which will remain in service is not allowed. Valves appurtenant to water mains to be abandoned may be abandoned in place in accordance with these specifications.

1.8.1.1 Valve Removal

The water system shall be shut down in accordance with the pertinent sections of these specifications.

The Contractor shall remove the valve, valve box, lid, riser pipe, concrete collar, and associated components. If the valve is attached directly to a flanged or mechanical joint fitting or tapping sleeve, the valve shall be removed and replaced with a blind flange or mechanical joint plug. If the valve is inline, or attached to an unrestrained fitting, the pipe, fitting and valve shall be neatly cut out, removed completely, and replaced with a new section of pipe. The system shall be re-pressurized and the Engineer shall inspect for leaks prior to backfilling.

All related work such as saw cutting, trenching, pipe installation, backfilling, and paving shall be executed in accordance with the pertinent sections of these specifications. If tracer wire is present, care shall be taken to maintain its continuity. If tracer wire is not continuous, it shall be spliced in accordance with the pertinent sections of these specifications.

The water system shall be re-pressurized, flushed, and sampled in accordance with the pertinent sections of these specifications.

1.8.1.2 Valve Abandonment

The Engineer shall confirm that the valve is closed. The Contractor shall remove the valve box, lid, concrete collar, and associated components, leaving the riser pipe in place. The hole above the valve shall be filled with slurry or concrete up to the bottom of the pavement section. All related work such as saw cutting and paving shall be executed in accordance with the pertinent sections of these specifications.

1.8.2 Pipeline Abandonment

The Contractor shall plug the ends of all abandoned pipelines where they have been cut open by the Contractor. This requirement applies to pipelines that the Contractor abandons, and to existing abandoned pipelines that the Contractor has cut to make way for new facilities.

Abandoned pipelines shall be plugged with concrete. The concrete shall be compacted into the pipe so that it forms a complete seal around the entire circumference of the pipe. Pipes abandoned in areas of steep slope or excessive groundwater may require additional plugging or grouting at the discretion of the Engineer.

1.8.3 Fire Hydrant Removal

The Contractor shall remove fire hydrants indicated for removal on the Contract Documents or by the Engineer. The fire hydrant buri shall be removed to a minimum 2 feet below grade and plugged with concrete. The concrete shall be compacted into the buri so that it forms a complete seal around the entire circumference of the pipe. Valves, valve boxes, paving and sidewalk shall be removed and/or

replaced in accordance with the pertinent sections of these specifications. The hydrant lateral shall be disconnected from the water main in accordance with the Contract Documents and these specifications. Salvaged hydrants shall be delivered to a District storage area at the request of the Engineer.

The Engineer shall notify the Fire District when hydrants are removed from or put into service.

1.8.4 Service Abandonment

The Contractor shall schedule a service line retirement with SVWD a minimum of two working days in advance of the proposed retirement. The Contractor shall expose the valve or corporation stop for SVWD personnel to operate. Only SVWD personnel may operate valves or corporation stops.

The service lateral shall be abandoned at the main unless indicated otherwise on the Contract Documents or by the Engineer. The service saddle, tapping sleeve, or other lateral connection appurtenance shall be removed and a full circle stainless steel repair clamp installed over the existing tap in the main.

The following alternative method of abandonment may be used if approved by the Engineer following inspection of the existing saddle and corporation stop. For service laterals attached to the main with a corporation stop, the service lateral shall be disconnected from the corporation stop by removal of the FIPxGrip Joint Adapter. The male iron pipe threads on the corporation stop shall be cleaned and prepared with tape and/or dope. A brass cap shall be tightened onto the corporation stop to prevent possible leakage. Older services that do not have MIP corporation stops shall be capped in another manner acceptable to the Engineer. The remaining service line shall be removed to a minimum depth of two feet.

For service laterals without corporation stops, the service lateral shall be disconnected from the valve, and the valve removed in accordance with the pertinent sections of these specifications. The remaining service line shall be removed to a minimum depth of two feet near the meter box and plugged with concrete in accordance with the pertinent sections of these specifications.

The meter box, related fittings and piping shall be removed. If the box is located in a sidewalk, the sidewalk shall be neatly saw cut and replaced at the nearest joint. All related work such as backfill, paving and site restoration shall be executed in accordance with the pertinent sections of these specifications, and the specifications of the applicable public works agency.

1.9 Pressure and Leakage Testing

1.9.1 Pressure and Leakage Tests

After the pipe has been laid and backfilled, the pipe, or any valve section thereof, shall be pressure tested in accordance with these specifications and applicable AWWA Standards.

Pressure and leakage tests shall not be performed until 72 hours have elapsed since the last concrete thrust block or reverse anchor has been cast, unless temporary blocking or other restraints have been provided to the Engineer's satisfaction.

Connections to the existing system, not included in the pressure and leakage tests, shall be visually inspected for leakage while under pressure prior to being fully backfilled in accordance with the pertinent sections of these specifications.

1.9.2 Pressure Test Procedure

The extent of new piping and number of appurtenances to be tested at one time shall be determined by the Engineer. In the case of systems with new services, the pressure test shall include all service piping up to the angle meter stop.

The water main shall be slowly filled with water through a SVWD provided hydrant meter or other backflow prevention device approved by the Engineer. Air shall be vented from all high points in the water main before making any pressure tests. Pipe shall be filled with water and pressurized at least 24 hours prior to testing to allow air to escape.

Where temporary bulkheads are used to test isolated portions of steel mains with O-Ring joints, the joints downstream from the temporary bulkhead will be welded in accordance with these specifications.

The test pressure shall be one and a half times the operating pressure at the average elevation, or 155 psi, whichever is greater. Where there are large changes in water main elevations, the test pressure will be determined by the Engineer.

The pressure shall be applied by means of a pump or backflow-protected jumper connection connected to the main in a manner satisfactory to the Engineer. The pressure shall be measured at the point(s) determined by the Engineer.

All materials and labor required for performing the pressure test shall be furnished by Contractor at no expense to the District. The Engineer may check the test pressure by installing a SVWD test gauge in place of or in addition to the Contractor's gauge. In case of a discrepancy between gauges, the Engineer's decision shall be final.

The hydrostatic pressure test shall be 2 hours duration. The allowable pressure drop is 5 psi, subject to the discretion of the Engineer.

With prior approval from the Engineer, the Contractor may at his convenience conduct a preliminary pressure test at any time prior to the SVWD pressure test. The results of the preliminary test will not be considered by the Engineer.

1.9.3 Leakage Test Procedure

A leakage test shall be performed if the pressure test reveals any observable pressure drop, or at the discretion of the Engineer.

The Contractor shall furnish the pump, pipe, connections and all other necessary apparatus and shall furnish all necessary assistance to conduct the test. SVWD may check the test pressure by installing a SVWD test gage in place of Contractor's gage. In case of a discrepancy between gauges, the Engineer's decision shall be final. The duration of the leakage test shall be 2 hours, and may be conducted at the same pressure as the pressure test. The pressure test and leakage test may be combined.

Leakage is defined as the quantity of water to be supplied into the newly-laid pipe, or any valved section thereof, necessary to maintain the specified leakage test pressure after the pipe has been filled with water and the air expelled. The Engineer shall measure the quantity of water added to maintain the specified leakage test pressure.

No pipe installation shall be accepted by the Engineer until the leakage is less than the number of gallons per hour as determined by the applicable formula.

$$L = \frac{ND\sqrt{P}}{7400} ; \quad \text{for PVC Pipe}$$

$$L = \frac{ND\sqrt{P}}{3700} ; \quad \text{for DI Pipe}$$

In which L equals the allowable leakage in gallons per hour; N is the number of joints in the length of pipeline tested; D is the nominal diameter of the pipe in inches; and, P is the average test pressure during the leakage test in pounds per square inch gauge. Allowable leakage for other pipe materials will be to the discretion of the Engineer.

Leakage is typically measured by leaving the pump used to conduct the pressure test attached to the main. At the end of the required two hour duration, the calculated acceptable leakage volume is placed in the feed bucket for the pump. The main is then pumped back up to the pressure at which the test began. If the water in the bucket runs out before the test pressure is reached, the main fails. The District may provide a meter when small leakage quantities must be measured accurately.

1.9.4 Test Failure

Should the main fail either test, the Contractor shall, at no expense to the District, locate and repair defects in the work or materials until the pipe is able to pass both tests. All repair work shall be executed in accordance with the pertinent sections of these specifications.

1.10 Disinfection and Testing

1.10.1 General

All water mains shall be successfully disinfected, flushed and verified in accordance with these specifications prior to connection to the existing system and prior to making service connections. The Contractor shall perform all flushing and disinfection operations. The Contractor shall provide a water quality sample point suitable to the Engineer. SVWD personnel shall draw the water sample(s), completed chain of custody documentation, and provide for compliance testing. The Contractor shall provide safe site access to SVWD personnel and maintain site conditions in accordance with the pertinent sections of these specifications.

The Contractor shall provide a minimum of 2 working days advance notice to SVWD when the main is ready for chlorination, unless approved in advance by the Engineer. Chlorination will only be conducted on Mondays and Tuesdays.

1.10.2 Disinfection of Mains

SVWD shall disinfect, test, flush and re-flush new water lines in accordance with AWWA Standard C651, and these specifications. The Contractor shall not make any connections to the pipeline until the pipeline has passed all laboratory tests.

1.10.3 Disinfection of Services

Service laterals shall be disinfected if required by the Engineer. Disinfection and testing shall be executed in a manner approved in advance by the Engineer.

1.10.3.1 Chlorination of New Pipelines

The new main and appurtenances shall be flushed and chlorinated with strict adherence to the method of application and precautions outlined in AWWA Standard C651, subject to the discretion of the Engineer. Chlorine shall be applied by the continuous feed method, slug method, or tablet method as outlined in AWWA Standard C651 except as modified by SVWD or the Engineer.

Water used to fill the new main shall be supplied through a temporary connection that shall include an appropriate cross-connection control device, consistent with the degree of hazard, for backflow protection of the active distribution system

When the continuous feed method is used, chlorine solution shall be fed into the pipe and left in contact with the pipe for no less than 24 hours. The initial free chlorine concentration shall be no less than 25 ppm. The concentration of free chlorine at the end of the contact time shall not be less than 40% of the starting concentration

The chlorine solution shall be flushed from the water main. Super-chlorinated water shall be dechlorinated before being discharged to storm drains or waterways. Super-dechlorinating is not necessary when discharging to a sanitary sewer. Flushing shall continue until the chlorine residual is less than 1 ppm, or typical system residual at that location, and turbidity is less than 0.5 NTU.

1.10.3.2 Urgent Disinfection

If the Engineer deems it necessary to disinfect a pipeline which must be returned to service at the end of the day, such as in the case of an existing pipeline which has become contaminated during an existing system connection (tie-in), the Contractor shall suspend any construction activities requested by the Engineer and coordinate with the Engineer to ensure that the contaminated water line is

disinfected to the satisfaction of the Engineer before being returned to service. All disinfection procedures shall be executed as determined by the Engineer

If in the opinion of the Engineer, an urgent disinfection is necessary due to reckless, incompetent or unclean construction practices on the behalf of the Contractor, the actual cost of said urgent chlorination plus standard overhead may be deducted from payments due to the Contractor from the District. No compensation of any kind shall be provided to the Contractor by the District for construction delays due to urgent disinfection. The Contractor shall not base any compensation claims, damage claims or time extension requests on any delays due to urgent disinfection.

1.10.4 Disinfection Testing

Following disinfection of the main, SVWD shall secure samples of the water from the water main for laboratory examination in accordance with AWWA Standard C651, and these specifications. Two sets of samples shall be collected, 24 hours apart.

Samples shall be taken from blow-offs or fire hydrants installed on the water main. Two samples for bacteriological (Bacti) testing and one sample for general physical (GP) testing shall be taken from each sampling point by SVWD. The sampling line may remain in place until testing produces satisfactory results or may be removed between samplings. If the sample pipe is left in place, the end of the pipe should be capped to prevent the entrance of dust or other contamination.

SVWD will notify Contractor of the results of the tests. Should either of the initial Bacti test samples indicate the presence of coliform bacteria or should any of the GP tests fail, flushing and sampling (both bacteriological and GP) shall be repeated once. If isolated sample points indicate coliform bacteria, flushing and re-sampling of only those points may be approved by SVWD. If satisfactory results are unachievable, the main must be re-chlorinated and re-sampled. After re-chlorination, if satisfactory results are still unachievable, the Contractor shall locate and remove the source of contamination. All remedial work shall be executed in accordance with the pertinent sections of these specifications.

If in the opinion of the Engineer, additional chlorination, flushing and testing is necessary due to reckless, incompetent or unclean construction practices on the behalf of the Contractor, the actual cost of said additional chlorination or flushing plus standard overhead may be deducted from payments due to the Contractor from the District or the cost may be charged to the Owner. No compensation of any kind shall be provided to the Contractor by the District for construction delays due to these requirements. The Contractor shall not base any damage claims or time extension requests on any delays due to these requirements.

After the disinfection produces satisfactory results, all temporary taps shall be securely closed and all sampling pipes removed. See Section 12.3 of these Specifications.

1.10.4.1 Special Additional Testing Requirements

If trench water enters the pipe during construction, or if in the opinion of the Engineer, the interior of the pipe is contaminated or excessively dirty, the Special Testing Procedures described in this section shall be followed.

The new main shall have been chlorinated and flushed by SVWD in accordance with these specifications. After final flushing and sampling, water shall be allowed to stand in the pipe for not less than 16 hours. After 16 hours have elapsed, samples of the water which stood in the pipe shall be taken at 200' intervals. The water main shall not be flushed out prior to this special sampling. Samples may be taken by attaching a meter to the outlet blow off, and taking one GP and two Bacti samples at each volume increment corresponding to 200' of pipe length.

If in the opinion of the Engineer, said Special Testing Procedures are required due to reckless, incompetent or unclean construction practices of the Contractor, the actual cost of said special testing plus standard overhead may be deducted from payments due to the Contractor from the District. No compensation of any kind shall be provided to the Contractor by the District for construction delays due to these special testing requirements. The Contractor shall not base any damage claims or time extension requests on any delays due to these requirements.

1.10.5 Contractor's Responsibility for Disinfection and Testing

Notwithstanding anything contained herein, it shall be the sole responsibility of Contractor to construct a water main capable of passing the pressure and leakage tests. The fact that SVWD provides inspection during the construction and pressure testing, and performs laboratory testing of the water mains shall not abrogate Contractor's responsibility in this regard.

It shall also be the responsibility of the Contractor to prevent the consumption of unsafe water by any person from a main which has not been determined to be safe by SVWD through disinfection and testing in accordance with these specifications. The Contractor shall indemnify and hold SVWD harmless from any suits, claims, or actions brought by any person or persons for or on account of any sickness or death sustained or arising from the consumption of water from any such main.

1.11 Work on the Existing System

1.11.1 Advance Notice of Shut Down

The Contractor shall request a system shut down at least 5 working days prior to the proposed commencement of any work which requires that the existing system be shut down. The Engineer shall determine the date, time and duration of the shutdown. If indicated by the Engineer, the Contractor shall hang SVWD-provided notification tags on the front door of each affected dwelling or place of business 3 working days in advance of the shut down. In general, shutdowns will be kept as short as possible and shall be made at times when there will be the least interference to the customers.

1.11.2 Operation of the Existing System

SVWD personnel shall close all valves in making a shutdown, open all valves in restoring pressure, and otherwise operate the existing system exclusively. The Contractor shall not operate any part of the existing system.

In the event that the Contractor operates the existing system and either directly damages the system, or in the opinion of the Engineer, causes indirect damage to the system, public or private property by causing the system to operate incorrectly, the costs for all repairs shall be borne by the Contractor. The Contractor shall pay the actual cost of repairs plus standard overhead. Such costs may be deducted by the District from any monies due or to become due to the Contractor under the Contract. No compensation of any kind shall be provided to the Contractor by the District for construction delays due to repair of the existing system by District forces. The Contractor shall not base any damage claims or time extension requests on any delays due to these requirements.

Any claims against the District and any fines levied to the District as a result improper system operation caused by the Contractor shall be borne by the Contractor. Such costs may be deducted by the District from any monies due or that will become due to the Contractor under the Contract.

1.11.3 Preparation

When work requires a system shut down, the Contractor shall prepare for such work as much as possible in advance. This preparation shall include but not be limited to potholing to determine the exact diameter and location of existing facilities, and having on site all parts and equipment necessary to complete the work. The system will be shut down only when the Contractor has made such preparations to the satisfaction of the Engineer.

1.11.4 Dewatering Operations

Prior to opening existing mains to make connections or repairs, mains shall be allowed to drain as much as possible through nearby hydrants or blow offs. The Contractor shall excavate a sump sufficiently deep to receive the residual water in the mains per Detail 17. Water shall be pumped out of the sump hole at a rate sufficient to prevent trench water from entering the mains. The Contractor shall ensure that pumps for trench dewatering are operational, primed, and otherwise properly set up and ready to begin pumping immediately at the moment of the main opening.

Water within the sump shall not be allowed to backflow into the water mains after it comes into contact with the trench. Should contaminated water flow into the system, the system shall be flushed and chlorinated as deemed necessary by the Engineer and in accordance with the pertinent sections of these specifications.

The Contractor shall prevent sediment laden trench water from being transported to storm drains or water bodies in accordance with the pertinent sections of these specifications. When practical, the Contractor

may prevent the water flowing into the trench from coming in contact with the earth in the trench. This may be achieved by placing a bucket underneath the draining water main and pumping out of the bucket. Water which is isolated from the trench in this manner may be dechlorinated and discharged directly to gutters or storm drains.

1.11.5 Leakage Inspection

Connections to the existing system and existing system repairs where proper pressure and leakage tests are not practical, shall be visually inspected by the Engineer for leakage while under pressure prior to being fully backfilled. Where conditions make such visual inspection unsafe, the Contractor shall install a temporary metallic pipe or conduit from all fittings to the ground surface to facilitate listening for leakage. Such temporary pipe shall be completely removed and the backfill recompacted prior to compaction testing and final paving

1.11.6 Tie-Ins

Upon passing the Bacti and GP tests, the Contractor shall make permanent connections between the new main and the existing system at the locations indicated by the Contract Documents or the Engineer. Advance notice shall be given to all customers affected, the system shall be shut down, drained, and connections made in accordance with the pertinent sections of these specifications.

In general, connections between new and existing mains will be made while the system has been shut down in accordance with the pertinent sections of these specifications, unless the Contract Documents call for a hot tap connection.

1.11.6.1 Connection Procedure

Where existing mains have been provided with fittings for the purpose of connecting to the new main, the Contractor shall remove any plugs or bulkheads, clean the ends, prepare them for connection to the new main and make the new joint in accordance with the pertinent sections of these specifications. Connections to existing mains shall be a minimum of 24 inches from other taps or fittings, as measured from outside edges.

All joints and fittings used in the connection shall be restrained in accordance with pertinent sections of these specifications, and Details 17 and 18. Flex couplings shall only be used in situations where restrained fittings cannot be used.

The Contractor shall install thrust blocks at all fittings used in the connection in accordance with pertinent sections of these specifications and Detail 19.

All pipe and fittings used to make the connection shall be cleaned and disinfected with a swab saturated with hypochlorite solution or by another means approved by the Engineer.

If possible, after the connection is complete and before backfilling, the connection shall be pressurized and the Engineer shall inspect all joints made during the system connection for leaks. If any leaks are found, they shall be repaired in accordance with pertinent sections of these specifications.

Section 2 Material Specifications

2.1 General

2.1.1 Scope

The purpose of Part II Material Specifications is to set forth the materials to be used in the construction of facilities which will become the property of SVWD. Any deviation from these standards must be approved by the Engineer.

All Materials in contact with potable water shall conform to the applicable AWWA Standard, and shall be certified by a ANSI accredited organization to be in compliance with NSF/ANSI 61.

2.1.2 General

All Materials shall be new and unused. Contractor shall install all materials as indicated on the drawings and specifications and consistent with the project material submittals. All materials delivered to the job site shall be adequately housed and protected to ensure the quality of the project.

The Contractor shall furnish, at the request of the Engineer, without additional cost to the District, such quantities of construction materials required for test purposes.

The SVWD reserves the right to direct or deny use of certain types of materials in specific circumstances.

2.1.3 Pre Approved Products

Some sections of these specifications list *Pre Approved Products*. These products are listed to provide an example of a material or part which SVWD has found to meet the requirements of these specifications. No preference toward a particular brand, series or model is implied by the *Pre Approved Product* listing.

2.2 Pipe

2.2.1 Brass Pipe

Brass pipe and nipples shall conform to AWWA C800 and these specifications and shall be certified by an ANSI accredited organization to be in compliance with NSF/ANSI 61. Brass parts shall consist of brass alloy having a lead content not more than 0.25 percent by weight. Brass shall meet the composition, chemical and mechanical requirements of C89520 or C89833 alloys as specified by the Copper Development Association, Inc.

Brass pipe shall be suitable for use at pressures not less than 150 psi.

2.2.1.1 Joints

Joints between brass pipe and adjacent fittings shall be iron pipe threaded. Soldered joints are prohibited.

2.2.2 Copper Pipe

All below-ground copper pipe shall be type K annealed (soft) seamless copper tubing conforming to ANSI/ASTM B88M and AWWA C800. Copper pipe that is kinked or has walls which have buckled shall be rejected and removed from the site.

Copper pipe used for aboveground piping such as risers for backflow prevention devices shall be type K drawn (hard) seamless copper tubing.

2.2.2.1 Joints

Joints in copper pipe shall be made with brass CTS grip joint fittings conforming to pertinent sections of these specifications. Soldered or flare joints are prohibited.

2.2.3 Ductile Iron Pipe

Ductile iron pipe shall conform to AWWA C151. The wall thickness of the ductile iron pipe shall be designed in accordance with AWWA C150. The class or nominal thickness, net weight without lining, and casting period shall be clearly marked on each length of pipe. Sticks of ductile iron pipe shall have standard lengths of either 18 feet or 20 feet. Random lengths are not acceptable.

2.2.3.1 Interior Lining

The interior of ductile iron pipe shall be cement mortar lined and bituminous seal coated in accordance with AWWA C104.

2.2.3.2 Exterior Coating

The exterior of ductile iron pipe shall have an asphaltic coating conforming to AWWA C151.

2.2.3.3 Polyethylene Encasement

Polyethylene Encasement for wrapping DI pipe shall conform to AWWA C105. Polyethylene wrap shall be clearly marked ANSI A21.5 / AWWA C105. Polyethylene wrap shall be 10-mil thick and provided from the factory in tube form. Sheets may be allowed at the discretion of the Engineer for encasing appurtenances.

2.2.3.4 Joints

Joints in DI pipe shall be push-on, mechanical, or flanged rubber gasket joints conforming to AWWA C111. Rubber gaskets and gasket lubricant shall be certified by an ANSI accredited organization to be in compliance with NSF/ANSI 61, and shall not impart taste or odor to water.

Push-on rubber gasket joints shall use the gasket provided by the factory for that particular joint. Swapping gaskets is not allowed.

Mechanical joint glands shall consist of ductile iron conforming to ASTM A536 and shall be protected from corrosion by a quality factory-applied coating. Nuts and bolts for mechanical joints and flanged joints shall either be stainless steel or protected against corrosion by a field-applied bitumastic coating approved by the Engineer.

Pre Approved Products:

Tyton Joint Pipe as manufactured by U.S. Pipe

Mechanical Joint Pipe as manufactured by U.S. Pipe

2.2.4 Polyvinyl Chloride Pipe

PVC pipe 4 to 12 inches in diameter shall conform to AWWA C900, be rated for a working pressure of 305 psi, and shall have an outside diameter to wall thickness dimension ratio of 14.

PVC pipe 14 to 48 inches in diameter shall conform to AWWA C905, be rated for a working pressure of 235 psi, and shall have an outside diameter to wall thickness dimension ratio of 18.

Each length of pipe shall be clearly marked with the applicable AWWA Standard, Pressure class, and dimension ratio. Sticks of PVC pipe shall have standard lengths of 20 feet. Random lengths are not acceptable.

Pipe which appears discolored or oxidized, or has gouges deeper than 10% of the wall thickness shall be rejected and removed from the job site.

2.2.4.1 Joints

Joints in PVC pipe shall be push-on rubber gasket joints conforming to AWWA C900 or C905 as applicable. Rubber gaskets and gasket lubricant shall be certified by an ANSI accredited organization to be in compliance with NSF/ANSI 61, and shall not impart taste or odor to water.

Push-on rubber gasket joints shall use the gasket provided by the factory for that particular type of joint. Swapping gaskets is not allowed.

Pre Approved Products:

Vinyttech AWWA C900 and C905 as Manufactured by Vinyttech Corporation

AWWA C-900 and C-905 Municipal Water Pipe as Manufactured by North American Pipe Corporation

Diamond C900 and C905 As Manufactured by Diamond Plastics Company

2.2.5 Welded Steel Pipe

Welded steel pipe shall conform to AWWA C200. Ends of sections of welded steel pipe shall be prepared for the type of joint set forth in the Contract Documents.

2.2.5.1 Interior Lining

The Interior of welded steel pipe shall be protected from corrosion with factory applied cement mortar lining in accordance with AWWA C205, liquid epoxy conforming to AWWA C210 or fusion bonded epoxy conforming to AWWA C213.

2.2.5.2 Exterior Coating

The exterior of welded steel pipe shall be protected from corrosion with hot-applied coal tar enamel and tape conforming to AWWA C203, or spiral wire reinforced cement mortar coating conforming to AWWA C205.

2.2.5.3 Joints

For flexible coupled field joints, ends of pipe shall be plain. Welded beads on the outside of the pipe shall be trimmed down so that the weld metal does not project above the surface of the adjacent metal for a distance back from the ends of the pipe of 6 inches, or as otherwise specified in the project specifications. Bolted, sleeve-type couplings for plain-end pipe shall conform to AWWA C219.

For Lap-Welded field joints, at least one end of each section shall be belled to provide a tight-fitting socket, which will allow a lap when the joint is assembled of at least 1 inch with the adjacent plain end of the next section of pipe.

For rubber-gasketed joints, the spigot ends shall have a groove to accommodate a round rubber gasket of the proper diameter and cross-section. The bell end shall be so shaped that, upon the insertion of a spigot into the bell, the gasket becomes deformed and completely fills the groove and, as the joint is closed, the gasket becomes completely enclosed by steel. The gasket shall be furnished with the pipe and shall provide the sole means of making the joint watertight.

For flanged joints, a steel slip-on weld flange of the specified size shall be welded to the end of the bare pipe before any coatings are applied.

2.3 Fittings

2.3.1 Bolted Sleeve Couplings (Flex Couplings)

Bolted sleeve couplings (flex couplings) shall conform to AWWA C219 and these specifications. Flex couplings shall consist of a carbon steel or stainless steel sleeve conforming to the material requirements of AWWA C200 or C220, respectively. The sealing mechanism at each end of the sleeve shall consist of a rubber gasket certified by an ANSI accredited organization to be in compliance with NSF/ANSI 61 and compressed by a stainless or carbon steel compression ring. The Compression ring shall be tensioned by a single nut and bolt which acts perpendicular to the pipe centerline. Sleeves larger than 12 inches may use two nuts and bolts to provide tension. All fasteners and washers shall consist of stainless steel.

Flex couplings shall provide for a minimum of 8 degrees of pipe deflection. Flex couplings shall have a working pressure of not less than 200 psi.

2.3.1.1 Interior/Exterior Coating

All non-stainless steel components of flex couplings shall be protected from corrosion by a fusion-bonded epoxy coating conforming to AWWA C213, or another quality factory-applied coating approved by the Engineer.

Pre Approved Products:

Hymax Couplings as manufactured by Total Piping Solutions, Inc.

2.3.2 Brass Fittings

Brass fittings shall conform to AWWA C800 and these specifications. Brass fittings shall consist of brass alloy having a lead content not more than 0.25 percent by weight. Brass shall meet the composition, chemical and mechanical requirements of C89520 or C89833 alloys as specified by the Copper Development Association, Inc.

Brass fittings shall be suitable for use at pressures not less than 150 psi.

2.3.2.1 Joints

Joints between brass fittings and copper pipe shall be made with iron pipe thread to CTS grip joint adapters. Joints between brass fittings and brass pipe shall be iron pipe threaded. Soldered joints or flare fittings are prohibited.

Pre Approved Products:

Low-lead brass fittings as manufactured by James Jones Company marked "EBII" or "FD"

No-lead brass fittings as manufactured by The Ford Meter Box Company, marked "NL"

2.3.3 Ductile Iron Fittings

Ductile iron fittings shall conform to AWWA C110 or C153, in material, body thickness and radii of curvature with the exception of laying lengths.

2.3.3.1 Interior Lining

Ductile iron fittings shall be lined with a bituminous seal-coated cement mortar lining conforming to AWWA C104.

2.3.3.2 Exterior Coating

Ductile iron fittings shall be coated with an asphaltic coating conforming to AWWA C110, or with fusion bonded epoxy conforming to AWWA C116.

2.3.3.3 Joints

Joints in DI fittings shall be push-on, mechanical or flanged rubber gasket joints conforming to AWWA C111. Rubber gaskets and gasket lubricant shall be certified by an ANSI accredited organization to be in compliance with NSF/ANSI 61 and shall not impart taste or odor to water.

Push-on rubber gasket joints shall use the gasket provided by the factory for that particular joint. Swapping gaskets is not allowed.

DI fitting joints shall include joint restraints conforming to the applicable sections of these specifications.

2.3.4 Welded Steel Fittings

Dimensions of welded steel fittings shall conform to AWWA C208.

Materials, linings, coatings and joint types of welded steel fittings shall be the same types as the welded steel pipe to which the fitting is to be attached and shall conform to the applicable sections of these specifications.

2.4 Joint Restraints

2.4.1 Joint Restraints for DI Push-On Joints

Joint restraints for DI pipe push-on joints shall consist of bell restraint harnesses and/or rubber gaskets with embedded locking elements. Joint restraints shall be capable of restraining the thrust force created at two times the rated working pressure of the pipe or fitting to which they are attached.

Bell restraint harnesses for DI push-on joints shall consist of two split-ring harnesses manufactured from ductile iron conforming to ASTM A536. One split-ring harness shall bear upon the back of the pipe bell. The other split-ring harness shall grip the spigot end of the adjacent pipe with individual bolt-tightened wedges. The wedges shall have a Brinell hardness number not less than 370. Wedge-tightening bolts shall be provided from the factory with heads which break away when proper torque is reached. The split-ring harnesses shall be connected and tensioned by threaded rods and nuts. The split-ring harnesses shall be protected against corrosion with a high quality factory-applied coating. Nuts, bolts, and threaded rods shall be either stainless steel or protected against corrosion with a field-applied bitumastic coating approved by the Engineer.

Locking gaskets shall consist of a rubber gasket conforming to AWWA C111 embedded with stainless steel toothed gripping elements.

Pre Approved Products:

Series 1700 or 1100HD Bell Restraint Harness as manufactured by EBAA Iron, Inc.

Field Lok 350 gaskets as manufactured by U.S. Pipe

2.4.2 Joint Restraints for Mechanical Joints with DI Pipe

Joint restraints for DI Mechanical Joints with DI pipe shall be capable of restraining the thrust force created at two times the rated working pressure of the pipe or fitting to which they are attached.

Joint restraints for mechanical joints shall consist of a ductile iron mechanical joint gland conforming to ASTM A536. The gland shall conform to AWWA C111 and shall grip the spigot end of the pipe with individual bolt-tightened wedges. The wedges shall have a Brinell hardness number not less than 370. Wedge-tightening bolts shall be factory provided with heads which break away when proper torque is reached. The DI gland shall be protected against corrosion with a high quality factory applied coating. Nuts and bolts shall be either stainless steel or protected against corrosion with a field-applied bitumastic coating approved by the Engineer.

Pre Approved Products:

Megalug Series 1100 or 1100SD as manufactured by EBAA Iron, Inc.

2.4.3 Joint Restraints for Mechanical Joints with PVC Pipe

Joint restraints for DI Mechanical joints with PVC pipe shall meet or exceed the requirements of ASTM F1674.

The gland shall consist of ductile iron conforming to ASTM A536 and shall conform to AWWA C111. Restraint shall be provided by individual bolt-tightened wedges which grip the spigot end of the adjacent pipe. Wedge-tightening bolts shall be factory provided with heads which break away when proper torque is reached. The spacing and number of bolt tightened wedges shall be designed by the manufacturer specifically for type of pipe they will grip. The DI gland shall be protected against corrosion with a high

quality factory applied coating. Nuts and bolts shall be either stainless steel or protected against corrosion with a field-applied bitumastic coating approved by the Engineer.

Pre Approved Products:

Megalug Series 1100 or 1100SD as manufactured by EBAA Iron, Inc.

2.4.4 Joint Restraints for PVC Push-On Joints

Joint restraints for PVC pipe push-on joints shall meet or exceed the requirements of ASTM F1674.

Joint restraints for PVC pipe push-on joints shall consist of bell restraint harnesses. Bell restraint harnesses for PVC pipe shall consist of two serrated split-ring, harnesses manufactured from ductile iron conforming to ASTM A536. One serrated split-ring harness shall grip the bell end of the pipe behind the bell. The other serrated split-ring harness shall grip the spigot end of the adjacent pipe. The serrated split-ring harnesses shall be tightened onto the pipe barrel with a bolt on either side. The two pipe gripping harnesses shall be connected by threaded rods and nuts. The ductile iron serrated split-ring harnesses shall be protected against corrosion with a quality factory-applied coating. Nuts, bolts and threaded rods shall be either stainless steel or protected against corrosion with a field applied bitumastic coating approved by the Engineer.

Pre Approved Products:

Series 1500 Bell Restraint Harness as manufactured by EBAA Iron, Inc.

2.5 Valves

2.5.1 Air Valves

Air Valves shall conform to AWWA C512. The interior linkage parts and fasteners shall consist of brass or stainless steel. Floats shall be plastic or stainless steel. The interior surfaces of air valves shall be coated in conformance with AWWA C550. Air valves shall be watertight.

2.5.1.1 Vacuum Relief Valve

Air/vacuum valves shall permit large volumes of air to exit or enter the pipe while the pipe is not under pressure.

Pre Approved Products:

S-1500 series Vacuum Relief Valve as manufactured by Apco Williamette Valve and Primer Corporation.

2.5.1.2 Air Release Valves

Air release valves shall permit release of small amounts of entrained air from the pipe, while the pipe is operating under pressure.

Pre Approved Products:

S-50 series or S-200A series Air Release Valve as manufactured by Apco Williamette Valve and Primer Corporation.

2.5.1.3 Combination Air Valves

Combination air valves shall perform the functions of both air/vacuum valves and air release valves. Valves smaller than 4" shall be self-contained in one unit, not a combination of two valves.

Pre Approved Products:

S-140c series As manufactured by Apco Williamette Valve and Primer Corporation.

AL series Air and Vacuum Valve As manufactured by Crispin Valve.

2.5.2 Backflow Prevention Assemblies

Only assemblies that appear on the list of approved devices maintained by SVWD are permitted for use. The Contractor shall verify that the device to be installed appears on the most recent SVWD list of approved devices.

Assemblies shall be shipped from the manufacturers in the fully assembled configuration. This includes bypass arrangements and shutoff valves. Assemblies received for installation not completely assembled are not approved. Field conversions of double check assemblies to a detector assembly, or vice versa, are not permitted.

2.5.3 Brass Valves

Brass valves shall conform to AWWA C800 and these specifications. Brass valves shall be certified by an ANSI accredited organization to be in compliance with NSF/ANSI 61. Brass valves shall consist of brass alloy having a lead content not more than 0.25 percent by weight. Brass shall meet the

composition, chemical and mechanical requirements of C89520 or C89833 alloys as specified by the Copper Development Association, Inc. Brass valves shall bear a mark from the manufacturer indicating that the fitting is composed of a no-lead or low-lead alloy.

Brass valves shall be suitable for use at pressures not less than 150 psi.

2.5.3.1 2 Inch Fire Service Gate Valves

2-inch gate valves shall be of all bronze construction (including valve stem and handle), female iron pipe thread by female iron pipe thread, wheel handle valves.

Pre Approved Products:

J-372 as manufactured by James Jones Company

2.5.3.2 Angle Meter Stops

Angle meter stops shall be equipped with heads which allow the angle meter stop to be locked in the off position.

Pre Approved Products:

Low-lead angle meter stops as manufactured by James Jones Company marked "EBII" or "FD"

No-lead angle meter stops as manufactured by The Ford Meter Box Company, marked "NL"

2.5.3.3 Corporation Stops

Corporation stops shall be male iron pipe thread by male iron pipe thread. Connection to copper service line shall be made with an iron pipe thread to CTS grip joint adapter

Pre Approved Products:

Low-lead brass corporation stops as manufactured by James Jones Company marked "EBII" or "FD"

No-lead brass corporation stops as manufactured by The Ford Meter Box Company, marked "NL"

2.5.4 Check Valves

2.5.4.1 Meter Check Valve

Meter check valves for use with 5/8-inch bypass meters shall consist of low-lead brass, shall be female iron pipe threaded on both ends, and shall be suitable for use at pressures not less than 150 psi.

Pre Approved Products: HS11-333NL as manufactured by The Ford Meter Box Company, marked "NL"

2.5.4.2 Backflow Devices

See "Backflow Prevention Assemblies"

2.5.5 Fire Hydrants

Fire hydrants shall include a hydrant head, hydrant bury and break-away features conforming to AWWA C503 and these specifications.

2.5.5.1 Hydrant Head

Hydrant heads shall be all 6-inch diameter wet-barrel units. Hydrant heads shall be of the “steamer” variety, having two 2 ½-inch outlets and one 4 ½-inch outlet.

Hydrant outlets shall have National Standard hose threads. Hydrant outlet valves shall be operable by a pentagon shaped nut. Outlets shall be capped. Caps shall consist of either bronze or plastic and shall contain a rubber gasket. Hydrant caps shall not have chains attached. All hydrants and caps shall be painted with “post international yellow” enamel.

Pre Approved Products:

860 Wet Barrel Hydrant as manufactured by the Clow Valve Company.

2.5.5.2 Hydrant Bury

The hydrant bury shall consist of ductile iron. The hydrant bury shall be sized so that the face of the flange is 2-4 inches above finished grade. The buried end of the hydrant bury shall be a mechanical joint conforming to AWWA C111. The interior and exterior of the hydrant bury shall be coated with fusion bonded epoxy which conforms to AWWA C116 and is certified by an ANSI accredited organization to be in compliance with NSF/ANSI 61.

Pre Approved Products:

Ductile Iron Hydrant Bury as manufactured by the Clow Valve Company

2.5.5.3 Break Away Features

The hydrant head shall be attached to the bury with a break away spool and stainless steel bolts and nuts.

One set of flange bolts shall be hollow break away bolts, having a combined ultimate strength less than the yield strength of the hydrant head or bury.

The break away spool shall consist of ductile iron and shall have an ultimate strength less than the yield strength of the hydrant head or bury. The interior of the break away spool shall be coated with fusion bonded epoxy coating which conforms to AWWA C116 and is certified by an ANSI accredited organization to be in compliance with NSF/ANSI 61. The exterior shall be primed and painted with “post international yellow” enamel to match the hydrant.

2.5.6 Main Line Valves

Underground main line valves and service valves 4 inches and larger in diameter shall be iron body, resilient seated gate valves conforming to AWWA C509 or C515.

The wedge or “gate” of the valve shall consist of bronze or ductile iron completely encapsulated with sealing rubber. The sealing rubber shall be permanently bonded to the wedge. The waterway of the valve shall have a diameter equal to the nominal diameter of the valve and be smooth, unobstructed, and free of surface irregularities.

The stem stuffing box shall be serviceable with valve fully open and subjected to full rated working pressure.

Valves shall be equipped with a 2-inch square ductile iron operating nut, and the valve shall open when turned to the left (counter-clockwise). Valve stems shall not rise out of the body when the valve is operated. The operating nut shall be securely keyed into the stem at the factory, and shall be capable of withstanding repeated operation to the satisfaction of the Engineer.

All bolts on the valve shall consist of stainless steel. Valves shall be equipped with o-ring seals at all pressure retaining joints.

2.5.6.1 Interior/Exterior Coating

All iron parts except the operating nut shall be coated with fusion bonded epoxy, conforming to AWWA C550 and certified by an ANSI accredited organization to be in compliance with NSF/ANSI 61.

2.5.6.2 Joints

Valve ends shall be either flanged or restrained mechanical joints conforming to AWWA C111, and pertinent sections of these specifications.

Pre Approved Products:

Resilient Seated Gate Valve as manufactured by the Clow Valve Company

2.6 Appurtances

2.6.1 Boxes and Lids

2.6.1.1 Non Traffic Rated Meter Boxes

Meter boxes which will not be subjected to vehicle loading shall consist of precast reinforced concrete. Lids shall be solid reinforced concrete. "reading lids" are not allowed. Lids shall be imprinted with the applicable markings at the factory. Meter box and lid dimensions shall be identical to those of the pre approved products listed below.

Pre Approved Products:

B16BOX (box) and – B16P-corner(lid) as manufactured by Christy Concrete Products, Inc.

B36BOX (box) and B36FL-P-corner (lid) as manufactured by Christy Concrete Products, Inc.

2.6.1.2 Traffic Rated Meter Boxes

Meter boxes which may be subjected to vehicle loads shall consist of precast reinforced concrete boxes with steel rims. Traffic rated meter boxes shall be capable of withstanding AASHTO H20 wheel loading. Box dimensions shall be identical to those of the pre approved products listed below. Lids shall consist of a single continuous piece of steel tread plate, with reinforcements on the underside. "Reading lids" are not allowed. Lids shall be bolted to the box with stainless steel bolts. Lids shall be welded with markings per the applicable SVWD Detail.

Pre Approved Products:

B1017BOX (box) and B1017-61JH-P (lid) as manufactured by Christy Concrete Products, Inc.

B1730BOX (box) and B1730-51JH-P (lid) as manufactured by Christy Concrete Products, Inc.

B3048BOX (box) and B3048-53JH-P (lid) as manufactured by Christy Concrete Products, Inc.

2.6.1.3 Valve Boxes

Valve boxes shall be precast reinforced concrete, with cast iron rims. Valve boxes shall be capable of withstanding H/20 vehicle loading. Valve box lids shall be cast iron, and shall be marked in accordance with Detail 12. Valve box lids shall be properly fitting and shall not rattle when driven over by a vehicle.

Valve box and lid dimensions shall be identical to those of the pre approved products listed below.

Pre Approved Products:

G05BOX (box) and G05C (lid) as manufactured by Christy Concrete Products, Inc.

2.6.2 Aboveground Enclosures

2.6.2.1 Air Valve Enclosures

Enclosures for aboveground air valve installations shall be cylindrical, and consist of steel solid sheet metal no thinner than 16-gauge. The size of the enclosure shall be as indicated by the Contract Documents, or approved in advance by the Engineer. Enclosures shall be protected from corrosion

by a high quality factory applied coating, and shall be repainted with “hunter green” enamel. If required by the Engineer, the enclosure shall consist of stainless steel. Enclosures shall provide for an SVWD pad lock in a manner acceptable to the Engineer.

Pre Approved Products:

Steel Air Valve Enclosure as manufactured by Pipeline Products, Inc.

2.6.2.2 Aboveground Meter Enclosures

Enclosures for aboveground meter installations shall consist of solid steel sheet metal. Enclosures shall be protected from corrosion by a high quality factory applied coating approved by the Engineer, but may be repainted by the customer or property owner. For larger installations, the Engineer may approve the use of expanded sheet metal. If required by the Engineer, the enclosure shall consist of stainless steel. Enclosures shall provide for both a water-customer-supplied padlock and an SVWD padlock to be attached and operated without interfering with the operation of the other, in a manner acceptable to the Engineer.

Pre Approved Products:

E1A Backflow Enclosure as manufactured by Placer Waterworks, Inc.

2.6.3 Radio Read Conduit

Radio read conduit shall consist of flexible corrugated non-metallic direct bury conduit. Size of conduit shall be as specified on Detail 2.

2.6.4 Repair Clamps

Repair clamps shall consist of a stainless steel band tensioned with stainless steel nuts and bolts. A water tight seal shall be provided by a waffled mat-type gasket certified by an ANSI accredited organization to be in compliance with NSF/ANSI 61.

Pre Approved Products:

EZ-MAX Repair Clamp as manufactured by Total Piping Solutions, Inc.

SS1 – Stainless Seal as manufactured by Romac Industries, Inc.

2.6.5 Tapping Saddles and Tapping Sleeves

Tapping saddles and sleeves shall conform to AWWA C800 and these specifications.

The subsections below are arranged in hierarchal order. Any tapping saddle or sleeve specified for a particular water main type may also be used on the water main types listed in the sections below it.

2.6.5.1 Tapping Sleeves for Steel Water Mains

Tapping sleeves used to tap steel water mains shall consist entirely of stainless steel, and utilize all stainless steel hardware. Tapping sleeves for services smaller than 4 inches shall have female iron pipe threads. Sleeves for services 4 inches and larger shall be flanged in accordance with AWWA C111. A water tight seal against the main shall be provided by a waffled mat-type gasket certified by an ANSI accredited organization to be in compliance with NSF/ANSI 61.

Pre Approved Products:

SST, SSTIII Stainless Steel Tapping Sleeve as manufactured by Romac Industries, Inc.

EZ-Tap Plus as manufactured by Total Piping Solutions, Inc.

FAST Tapping Sleeve as manufactured by The Ford Meter Box Company, Inc.

2.6.5.2 Tapping Saddles for PVC Water Mains

Tapping saddles used to tap PVC water mains shall consist entirely of brass or bronze, and utilize all brass or bronze hardware. Tapping saddles shall have female iron pipe threads of the appropriate size. Tapping saddles shall be equipped with a single, wide strap which fully encircles the main. The strap shall not be hinged to the tapping saddle, but shall attach with bolts on both sides. Watertight seal against the main shall be provided by a rubber gasket certified by an ANSI accredited organization to be in compliance with NSF/ANSI 61.

Pre Approved Products:

S91, Design B as manufactured by The Ford Meter Box Company, Inc.

2.6.5.3 Tapping Saddles for A-C and CI Water Mains

Tapping saddles used to tap A-C and CI water mains shall consist entirely of brass or bronze, and utilize all brass or bronze hardware. Tapping saddles shall have female iron pipe threads of the appropriate size. Tapping saddles shall have dual straps which connect to the saddle on both sides with bolts, and fully encircle the main. Watertight seal against the main shall be provided by a rubber gasket certified by an ANSI accredited organization to be in compliance with NSF/ANSI 61.

Pre Approved Products:

202B as manufactured by The Ford Meter Box Company, Inc.

2.6.5.4 Tapping Saddles for DI Mains

Tapping saddles used to tap DI mains shall consist entirely of brass or bronze, and utilize all brass or bronze hardware. Tapping saddles shall have female iron pipe threads of the appropriate size. Straps shall not be hinged to the tapping saddle, but shall attach to the saddle on both sides with bolts, and fully encircle the main. Watertight seal against the main shall be provided by a rubber gasket certified by an ANSI accredited organization to be in compliance with NSF/ANSI 61.

Pre Approved Products:

101B as manufactured by The Ford Meter Box Company, Inc.

2.6.6 Wrapping Tape

Pipe wrapping tape shall be 2" wide 10-mil polyvinyl tape.

Pre Approved Products:

Polyvinyl pipe tape as manufactured by Calpico, Inc.

2.6.7 Wood Blocking & Posts

Wood shall be redwood or pressure treated fir.

2.7 Backfill & Pavement

2.7.1 Backfill Material

Backfill material shall conform to the requirements of the applicable public works agency. If that agency has no published or readily available standards, backfill material shall conform to the requirements listed in the following sections.

2.7.1.1 Sand

Sand shall be clean, free of clay, debris, and organic or deleterious material. Sand shall conform to the following grading requirements.

100% passing the No. 4 sieve.

80-95% passing the No. 8 sieve.

Not more than 5% passing the No. 200 sieve.

2.7.1.2 Aggregate Base

Aggregate base shall be clean, free of clay, debris, organic and deleterious material.

Aggregate base shall be Class 2 Aggregate Base, $\frac{3}{4}$ " maximum conforming to Section 26 of the CalTrans Standard Specifications. Aggregate base shall conform to the following grading requirements.

100% passing the 1" sieve.

90-100% passing the $\frac{3}{4}$ " sieve.

35-60% passing the No. 4 sieve.

10-30% passing the No. 30 sieve.

2-9% passing the No. 200 sieve.

2.7.1.3 CLSM

Controlled low strength material (CLSM) shall be 1-sack cement sand slurry with a slump of 7 to 9 inches and a 28 day unconfined compressive strength of 50 to 150 psi. CLSM shall be mixed in a transit mixer. Certification tickets shall be submitted at the request of the Engineer. Where CLSM2 is called for by Detail or the Engineer, a 2-sack cement sand slurry shall be provided by the Contractor.

2.7.2 Pavement

Pavement shall conform to the requirements of the applicable public works agency. If that agency has no published or readily available standards, pavement shall conform to the requirements listed in the following sections.

2.7.2.1 Asphalt Concrete

Asphaltic concrete shall be Type B, or better, conforming to Section 39 of the CalTrans Standard Specifications. Type A asphaltic concrete may be substituted for Type B if it is required by another

agency, design engineer or is delivered to site instead of Type B. Gradations shall be per the specifications of the appropriate public works agency.

2.7.2.2 Portland Cement Concrete

All concrete shall be Portland cement concrete and shall be composed of Type II or Type V portland cement conforming to ASTM C150, fine and coarse aggregates, water and admixtures. Portland cement concrete shall be proportioned and mixed as required to produce a smooth, workable mixture. It shall have a minimum ultimate compressive strength of 3,000 psi as determined by ASTM C873. The maximum size of aggregate shall be that which passes a 1" mesh screen. Concrete shall not contain less than 6 sacks (565 lbs) of cement per cubic yard.

2.7.2.3 Concrete Reinforcement

Reinforcing bars shall conform to ASTM A615. All bars shall be deformed.

Welded wire mesh reinforcement may be plain or deformed. Plain wire shall conform to ASTM A185. Deformed wire shall conform to ASTM A497.

2.8 Miscellaneous

2.8.1 Disinfection Materials

Chlorine (bleach) used for disinfection may be either liquid chlorine or sodium hypochlorite solution. Calcium hypochlorite shall not be used unless approved in advance by the Engineer. Chlorine shall be certified by an ANSI accredited organization to be in compliance with NSF/ANSI 60.

All materials used for disinfection of water mains such as jumper hoses and fittings shall be certified by an ANSI accredited organization to be in compliance with NSF/ANSI 61.

Chlorine neutralizing material shall consist of ascorbic acid.

2.8.2 Temporary Materials

Materials used for temporary facilities shall consist of materials which will safely perform their intended purpose for the duration of their intended life. Temporary materials are subject to the approval of the Engineer. Temporary materials which will contact potable water shall be certified by an ANSI accredited organization to be in compliance with NSF/ANSI 61.

Section 3 Standard Details

Detail 1 - Service Connection	62
Detail 2 - Meter Box Installation.....	63
Detail 3 - 1-inch and Smaller Multiple Branched Service Installation.....	64
Detail 4 Retrofit - Combination 2-inch Fire and Domestic Service Installation	65
Detail 4b- Combination 2-inch and Smaller Fire and Domestic Service Installation.....	66
Detail 5 - 2-inch and Smaller Service Installation.....	67
Detail 6 - 3-inch and Larger Service Installation	68
Detail 8 - 2-inch and Smaller Backflow Prevention Assembly Installation	69
Detail 9 - Standard 4-inch and Larger Fire Service Installation.....	70
Detail 9a- Vertical 2-inch and Smaller Fire Service BFD Installation.....	71
Detail 10 - Fire Hydrant Installation	72
Detail 11 - Gate Valve Installation	73
Detail 12 - Valve Box Lid Markings.....	74
Detail 13 - Valve Box Installation.....	75
Detail 14 - Standard Service Lateral Trench	76
Detail 15 - Standard Water Main Trench.....	77
Detail 16 - Sub-Standard Water Main Trench	78
Detail 17 - System Connection (Tie in).....	79
Detail 18 - Joint Restraint Installation.....	80
Detail 19 - Thrust Block Installation	81
Detail 20 - Traffic Bollard Installation.....	82
Detail 21 - Sample Station Installation	83
Detail 22 - Chlorination Tap Installation	84
Detail 23 - Blow Off Installation	85
Detail 24 - Air Valve Installation.....	86
Detail 25 - Below Grade Air Valve Installation.....	87

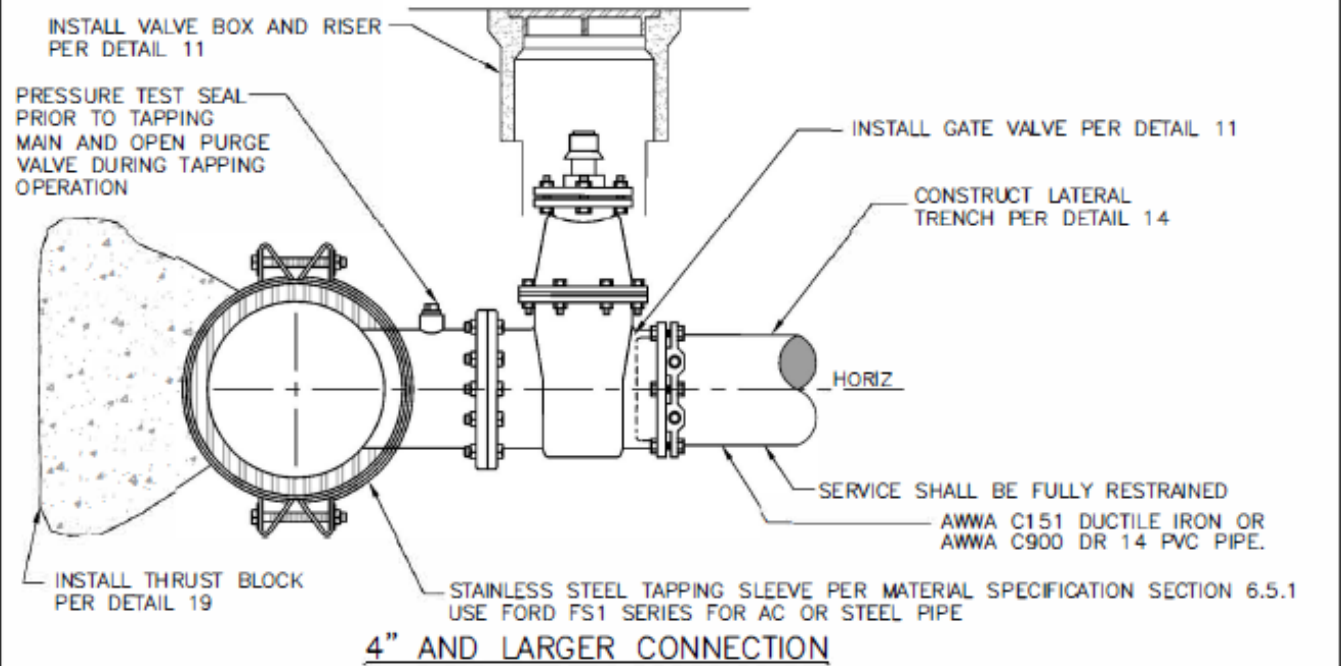
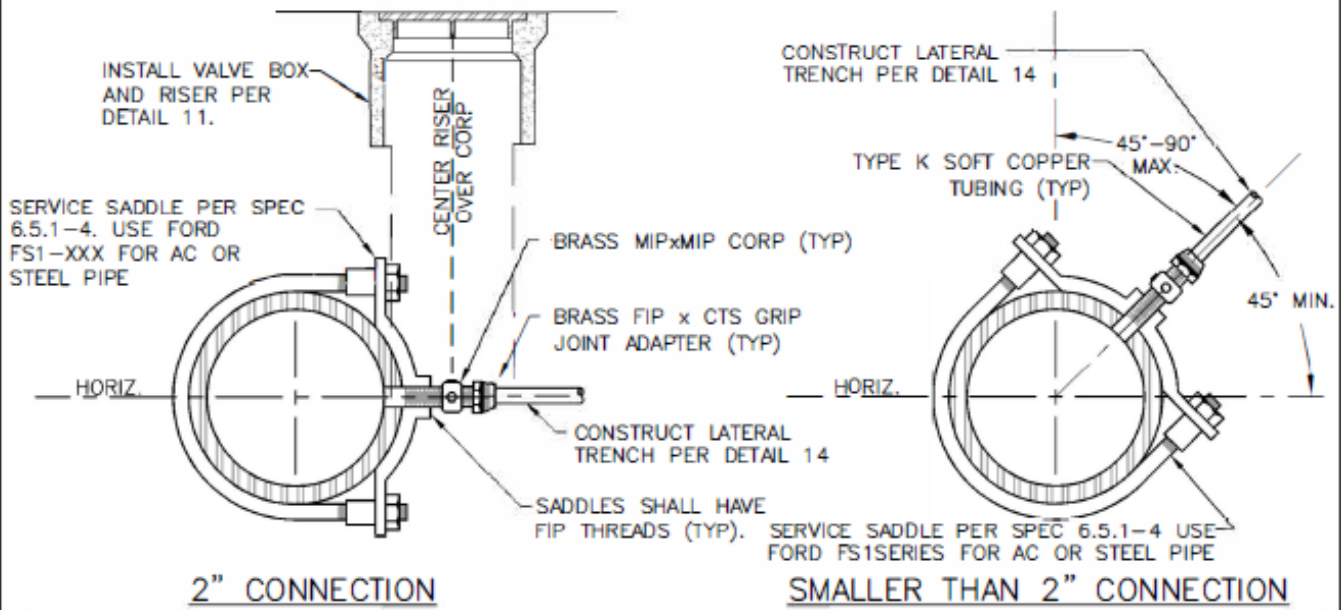

NOTES

1. ALL HOT TAP CONNECTIONS SHALL BE MADE IN THE PRESENCE OF THE ENGINEER.
2. ALL HOT TAP CONNECTIONS SHALL BE AT LEAST 24" AWAY FROM ANY JOINT OR FITTING AND 18" AWAY FROM ANY OTHER TAP.
3. CONTRACTOR SHALL OPEN PURGE VALVE DURING TAPPING OPERATION.
4. SERVICE PIPING AND FITTING DIAMETERS SHALL MEET OR EXCEED THE SERVICE SIZE DESIGNATED BY THE ENGINEER.
5. TAPPING BIT SHALL BE OF THE HOLE-SAW OR SHELL TYPE.
6. COUPON OR "COOKIE" SHALL BE SUBMITTED TO THE ENGINEER UPON REQUEST.
7. IF COUPON IS LOST, CONTRACTOR SHALL FULLY OPEN SERVICE IN THE PRESENCE OF THE ENGINEER TO VERIFY FLOW.
8. CONTRACTOR SHALL COAT TAPPING SADDLE, ALL FASTENERS AND SERVICE LINE WITH BITUMASTIC AND/OR ENCASE IN POLYETHYLENE IF DIRECTED BY THE ENGINEER.
9. CONNECTIONS TO MAINS SMALLER THAN 4" SHALL BE SPECIFIED ON A CASE BY CASE BASIS.
10. SERVICE SHALL BE DISINFECTED IF REQUIRED BY THE ENGINEER.

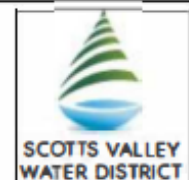

SCOTTS VALLEY WATER DISTRICT
 WWW.SVWD.ORG
DETAIL 1
 SERVICE CONNECTION
 NOT TO SCALE

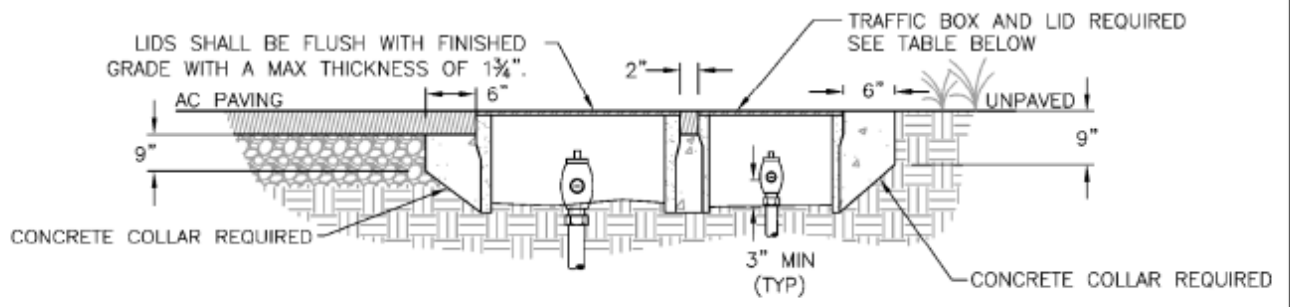
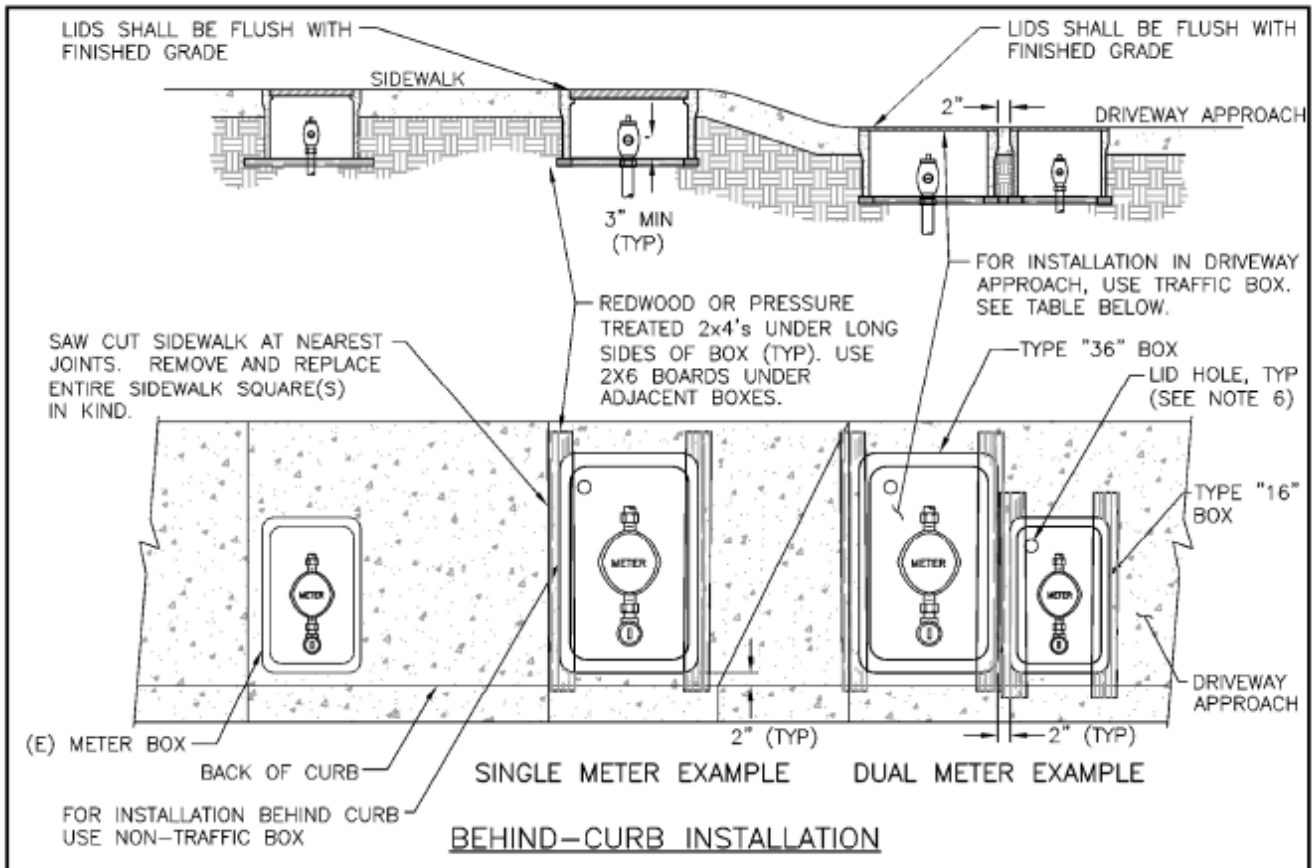

BOX TYPE	NON-TRAFFIC	TRAFFIC
TYPE "16"	CHRISTY B16 BOX W/ B16P [®] LID OR EQUAL	CHRISTY B1017 BOX W/ B1017-JH LID OR EQUAL
TYPE "36"	CHRISTY B36 BOX W/ B36P [®] LID OR EQUAL	CHRISTY B1730 BOX W/ B1730-51JH LID OR EQUAL
TYPE "36"	" FL36T BOX W/ FL36P [®] LID OR EQUAL	

NOTES
 1. LIDS TO BE PURCHASED FROM SVWD

SCOTTS VALLEY WATER DISTRICT
 WWW.SVWD.ORG

DETAIL 2

METER BOX INSTALLATION

NOT TO SCALE

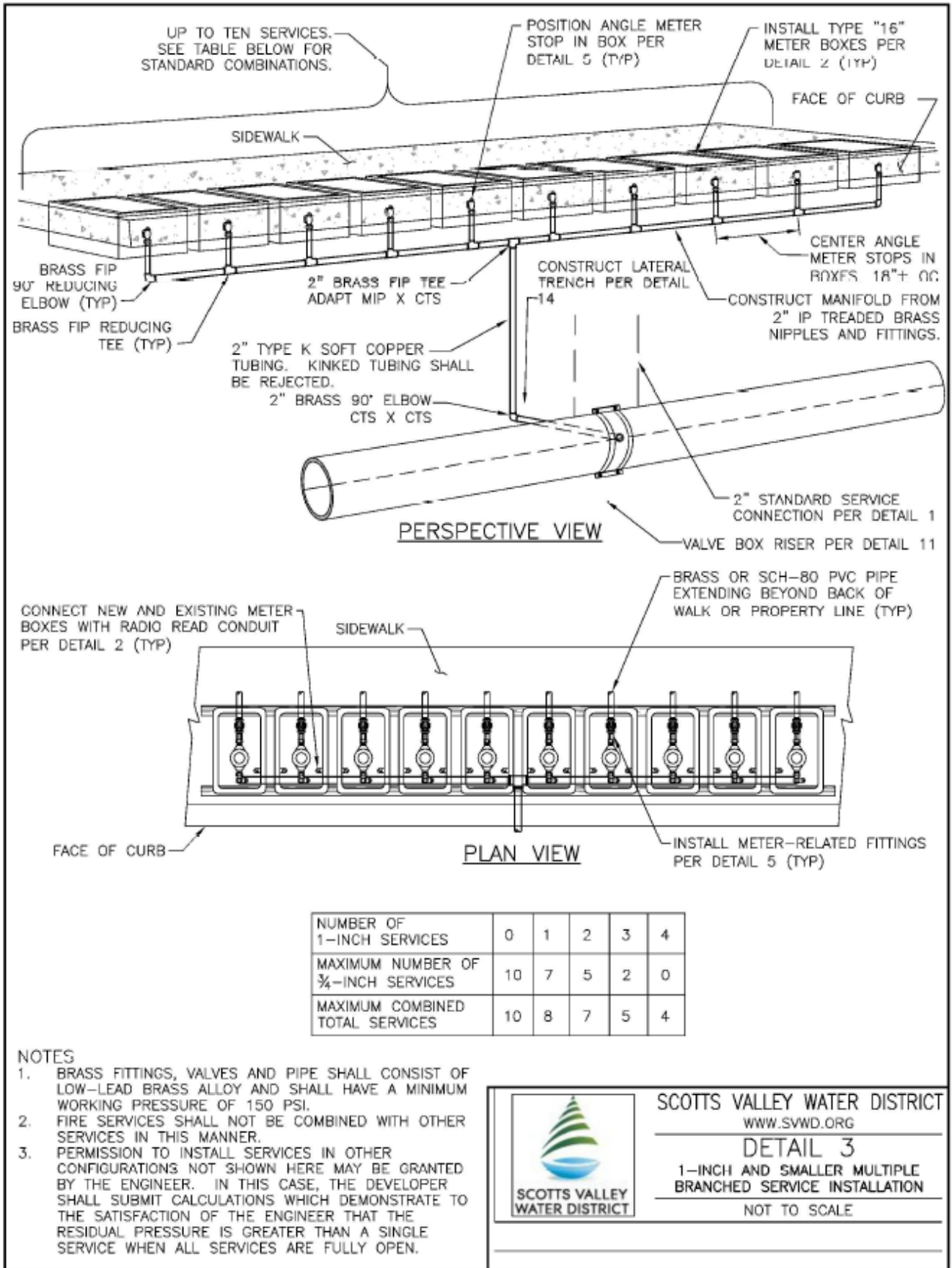

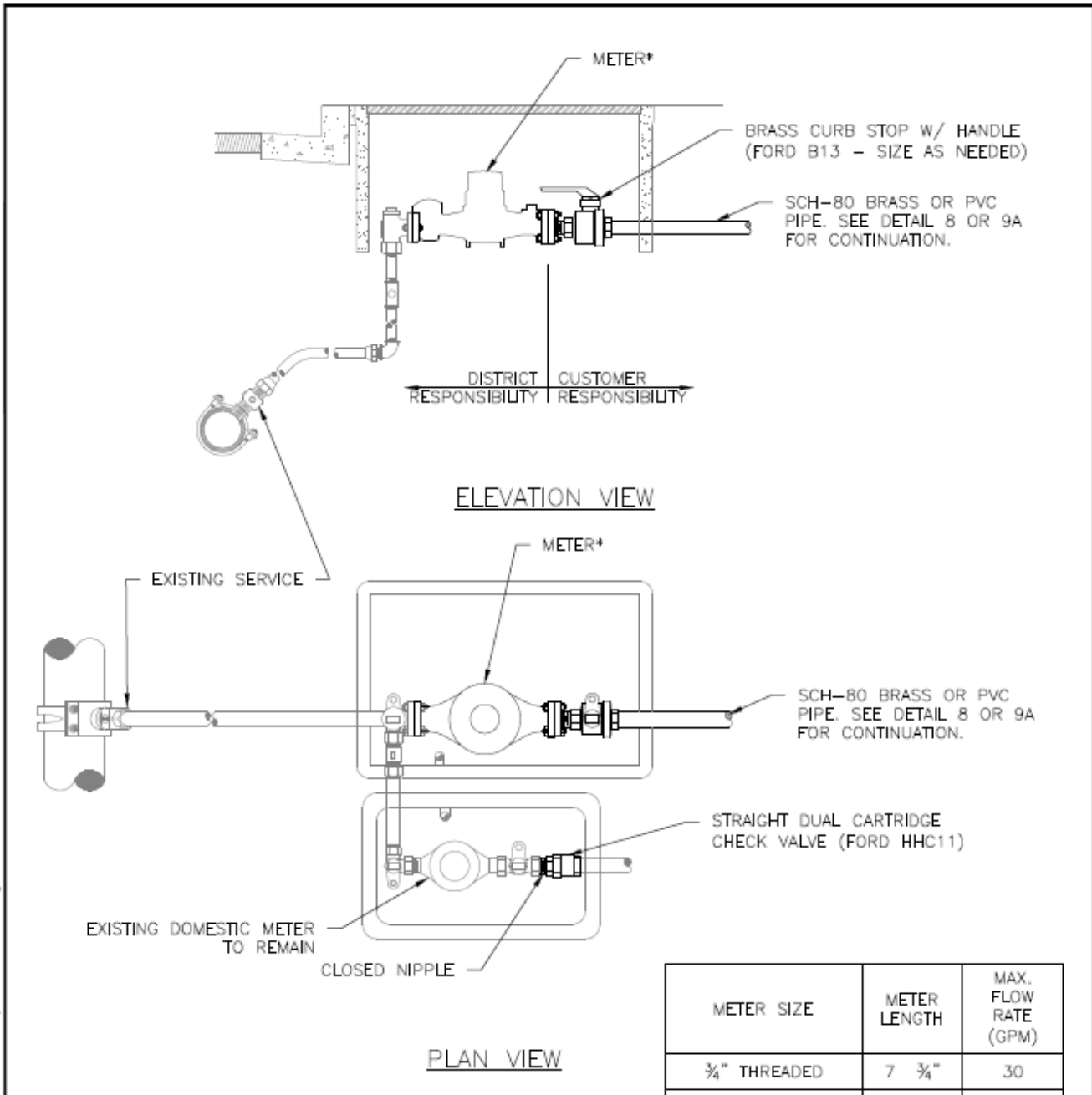

C:\Users\Tahira\Desktop\work\svwd\0424\04 06 09-civil\DETAILS-working\DETAIL 4 RETROFIT.dwg

NOTES

- 1. FIRE SERVICE METER AND FIRE SERVICE BFD TO BE SIZED BY OTHERS
- 2. METER FLANGES, ADAPTERS GASKET, BRASS NIPPLES AND STAINLESS STEEL NUTS AND BOLTS AS NEEDED TO COMPLETE RETROFIT, FORD METER BOX COMPANY OR APPROVED EQUAL.
- 3. BRASS FITTINGS, VALVES AND PIPE SHALL CONSIST OF LOW-LEAD BRASS ALLOY AND SHALL HAVE A MINIMUM WORKING PRESSURE OF 150 PSI.
- 4. FIRE SERVICE LINE SHALL BE TESTED FOR LEAKS PRIOR TO BACKFILLING.
- 5. CUSTOMER SIDE FIRE SERVICE PIPE TYPE AND CONNECTION SHALL MEET LOCAL FIRE AGENCY REQUIREMENTS.
- 6. ALL FITTINGS BETWEEN DISTRICT METER AND BACKFLOW DEVICE SHALL BE NSF 61 CERTIFIED MATERIAL.

METER SIZE	METER LENGTH	MAX. FLOW RATE (GPM)
¾" THREADED	7 ¾"	30
1" THREADED	11"	50
1 ½" FLANGED	13 ¼"	100
2" FLANGED	17"	160

SCOTTS VALLEY WATER DISTRICT
WWW.SVWD.ORG

DETAIL 4 RETROFIT
COMBINATION FIRE AND DOMESTIC SERVICE RETROFIT

NOT TO SCALE

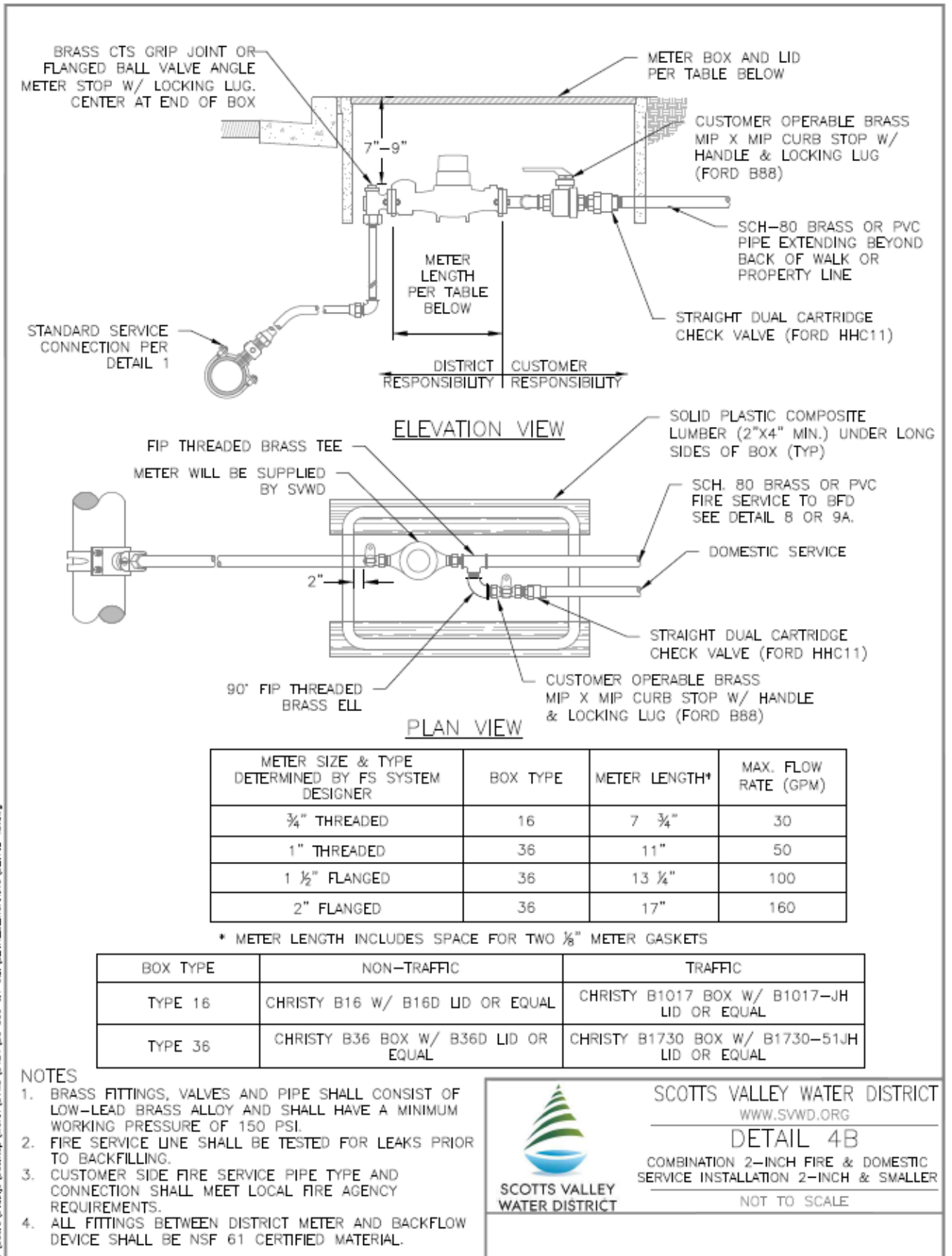

C:\Users\Traflet\Desktop\WORK\SVWD\SVWD\0424\06 008 01-cd\METALS_WORKING\DETAIL 4B.dwg

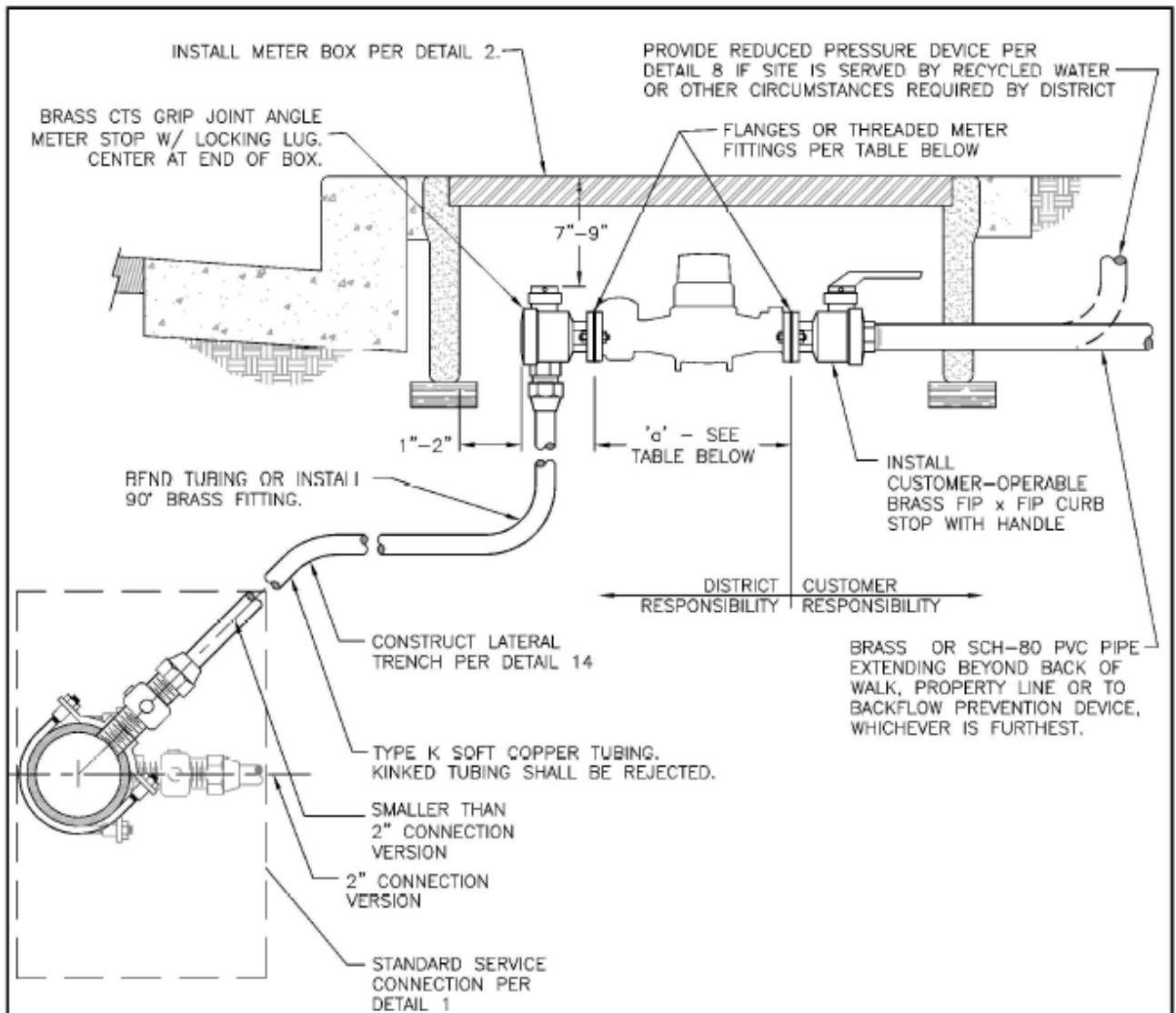

METER SIZE AND TYPE (ASSIGNED BY SVWD)	BOX TYPE (SEE DETAIL 2)	METER LENGTH, α
5/8" THREADED	"16"	7 3/4"
3/4" THREADED	"16"	7 3/4"
1" THREADED	"16"	11"
1 1/2" FLANGED	"36"	13"
2" FLANGED	"36"	15 1/4"

NOTES

- BRASS FITTINGS, VALVES AND PIPE SHALL CONSIST OF LOW-LEAD BRASS ALLOY AND SHALL HAVE A MINIMUM WORKING PRESSURE OF 150 PSI.
- METER WILL BE FURNISHED AND INSTALLED BY DISTRICT
- A BACKFLOW PREVENTION ASSEMBLY SHALL BE INSTALLED PER DETAIL B IF REQUIRED BY THE ENGINEER.



SCOTTS VALLEY WATER DISTRICT
WWW.SVWD.ORG
DETAIL 5
**2-INCH AND SMALLER SERVICE
 INSTALLATION**
 NOT TO SCALE

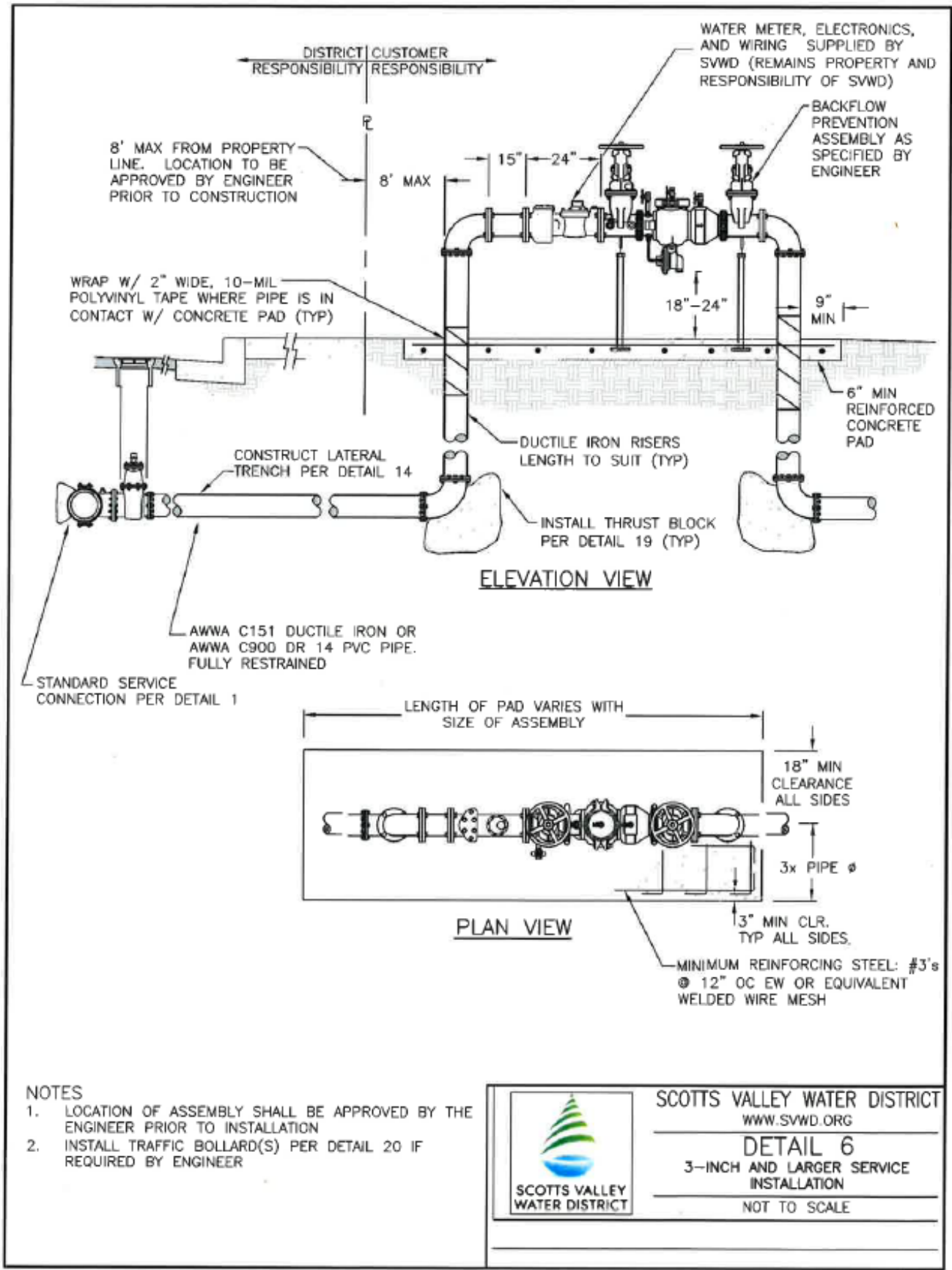

- NOTES**
1. LOCATION OF ASSEMBLY SHALL BE APPROVED BY THE ENGINEER PRIOR TO INSTALLATION
 2. INSTALL TRAFFIC BOLLARD(S) PER DETAIL 20 IF REQUIRED BY ENGINEER



SCOTTS VALLEY WATER DISTRICT
WWW.SVWD.ORG

DETAIL 6
3-INCH AND LARGER SERVICE INSTALLATION

NOT TO SCALE

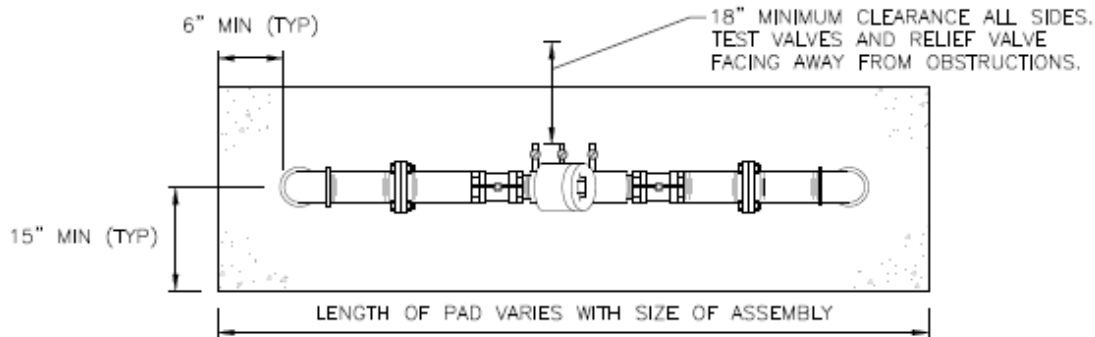
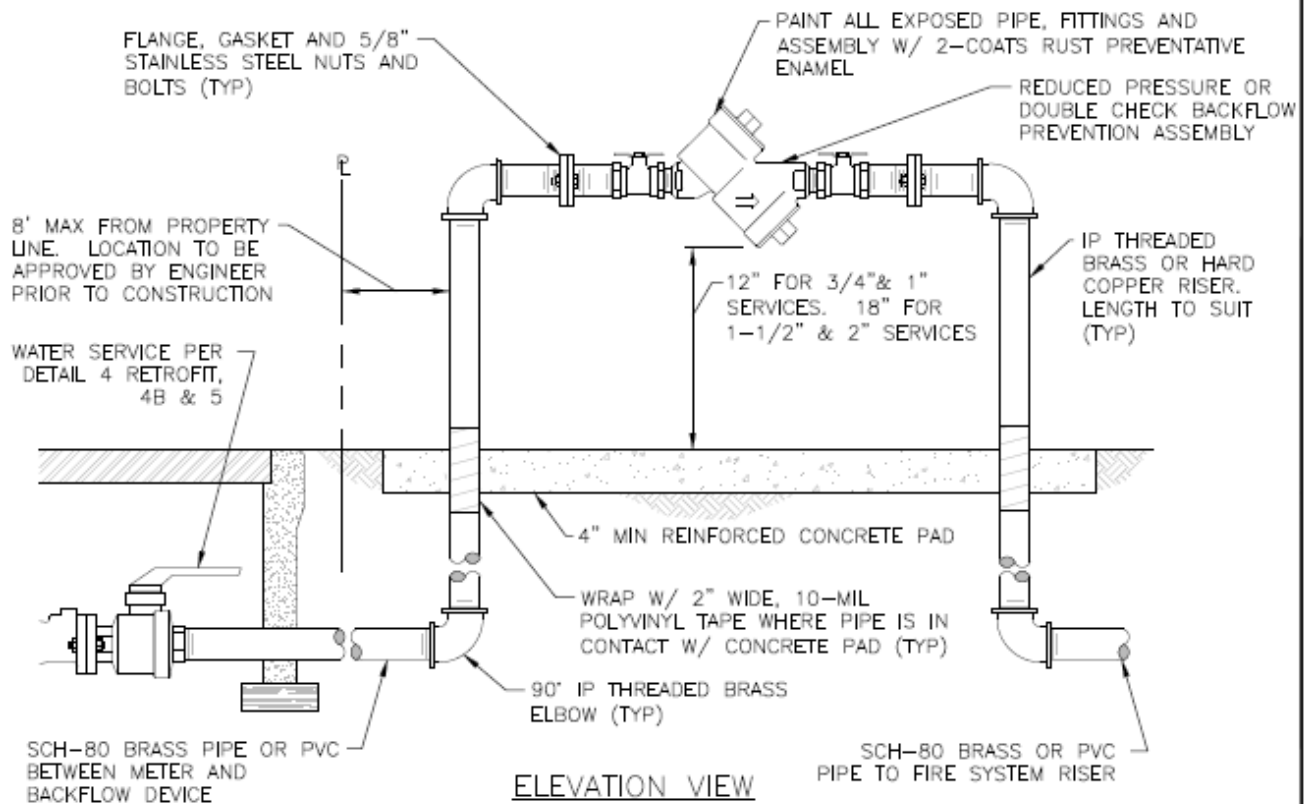

NOTES

1. APPROVED BACKFLOW ASSEMBLY SHALL BE INCLUDED IN THE CURRENT "LIST OF APPROVED BACKFLOW PREVENTION ASSEMBLIES," FOUNDATION FOR CROSS-CONNECTION AND HYDRAULIC RESEARCH, USC, SCHOOL OF ENGINEERING. APPROVED ASSEMBLY SHALL BE INSTALLED SUCH THAT IT IS READILY ACCESSIBLE FOR REPAIR AND INSPECTION.
2. BRASS FITTINGS, VALVES AND PIPE SHALL CONSIST OF LOW-LEAD BRASS ALLOY AND SHALL HAVE A MINIMUM WORKING PRESSURE OF 150 PSI.
3. BRASS OR PLASTIC PLUGS SHALL BE INSTALLED ON ALL TEST PORTS.
5. ALL FITTINGS BETWEEN DISTRICT METER AND BACKFLOW DEVICE SHALL BE NSF 61 CERTIFIED MATERIAL.
6. ALL ABOVE GROUND PIPE, FITTINGS AND ASSEMBLY SHOULD BE PAINTED WITH TWO COATS OF ENAMEL.
7. AN ENCLOSURE OR CAGE MAY BE INSTALLED AT THE OPTION OF THE PROPERTY OWNER.

 SCOTTS VALLEY WATER DISTRICT	SCOTTS VALLEY WATER DISTRICT WWW.SVWD.ORG
	DETAIL 8
	2-IN & SMALLER BACKFLOW PREVENTION ASSEMBLY INSTALLATION
	NOT TO SCALE

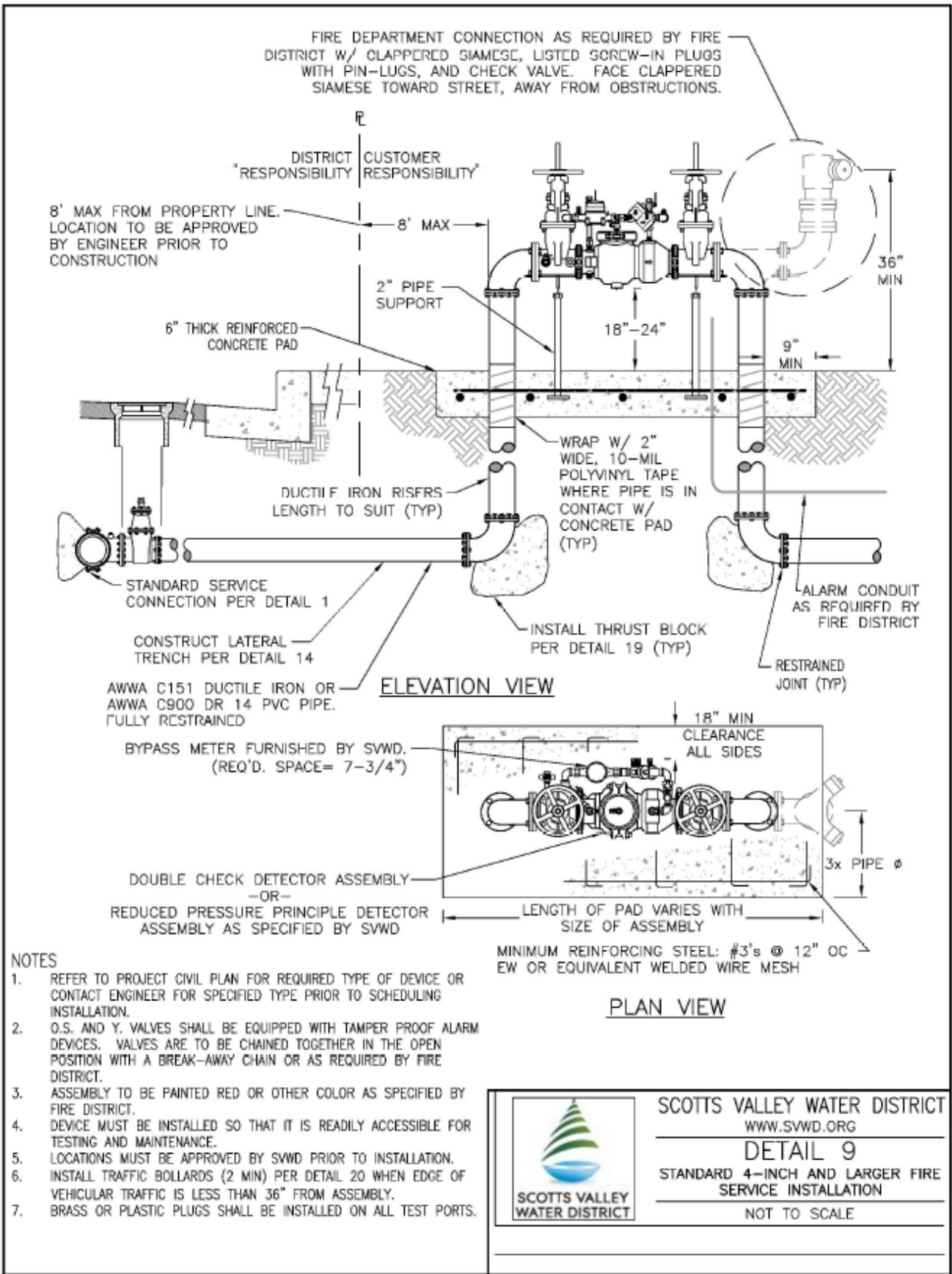

- NOTES**
1. REFER TO PROJECT CIVIL PLAN FOR REQUIRED TYPE OF DEVICE OR CONTACT ENGINEER FOR SPECIFIED TYPE PRIOR TO SCHEDULING INSTALLATION.
 2. O.S. AND Y. VALVES SHALL BE EQUIPPED WITH TAMPER PROOF ALARM DEVICES. VALVES ARE TO BE CHAINED TOGETHER IN THE OPEN POSITION WITH A BREAK-AWAY CHAIN OR AS REQUIRED BY FIRE DISTRICT.
 3. ASSEMBLY TO BE PAINTED RED OR OTHER COLOR AS SPECIFIED BY FIRE DISTRICT.
 4. DEVICE MUST BE INSTALLED SO THAT IT IS READILY ACCESSIBLE FOR TESTING AND MAINTENANCE.
 5. LOCATIONS MUST BE APPROVED BY SVWD PRIOR TO INSTALLATION.
 6. INSTALL TRAFFIC BOLLARDS (2 MIN) PER DETAIL 20 WHEN EDGE OF VEHICULAR TRAFFIC IS LESS THAN 36" FROM ASSEMBLY.
 7. BRASS OR PLASTIC PLUGS SHALL BE INSTALLED ON ALL TEST PORTS.

 <p>SCOTTS VALLEY WATER DISTRICT</p>	<p>SCOTTS VALLEY WATER DISTRICT</p> <p>WWW.SVWD.ORG</p>
	<p>DETAIL 9</p>
	<p>STANDARD 4-INCH AND LARGER FIRE SERVICE INSTALLATION</p>
	<p>NOT TO SCALE</p>

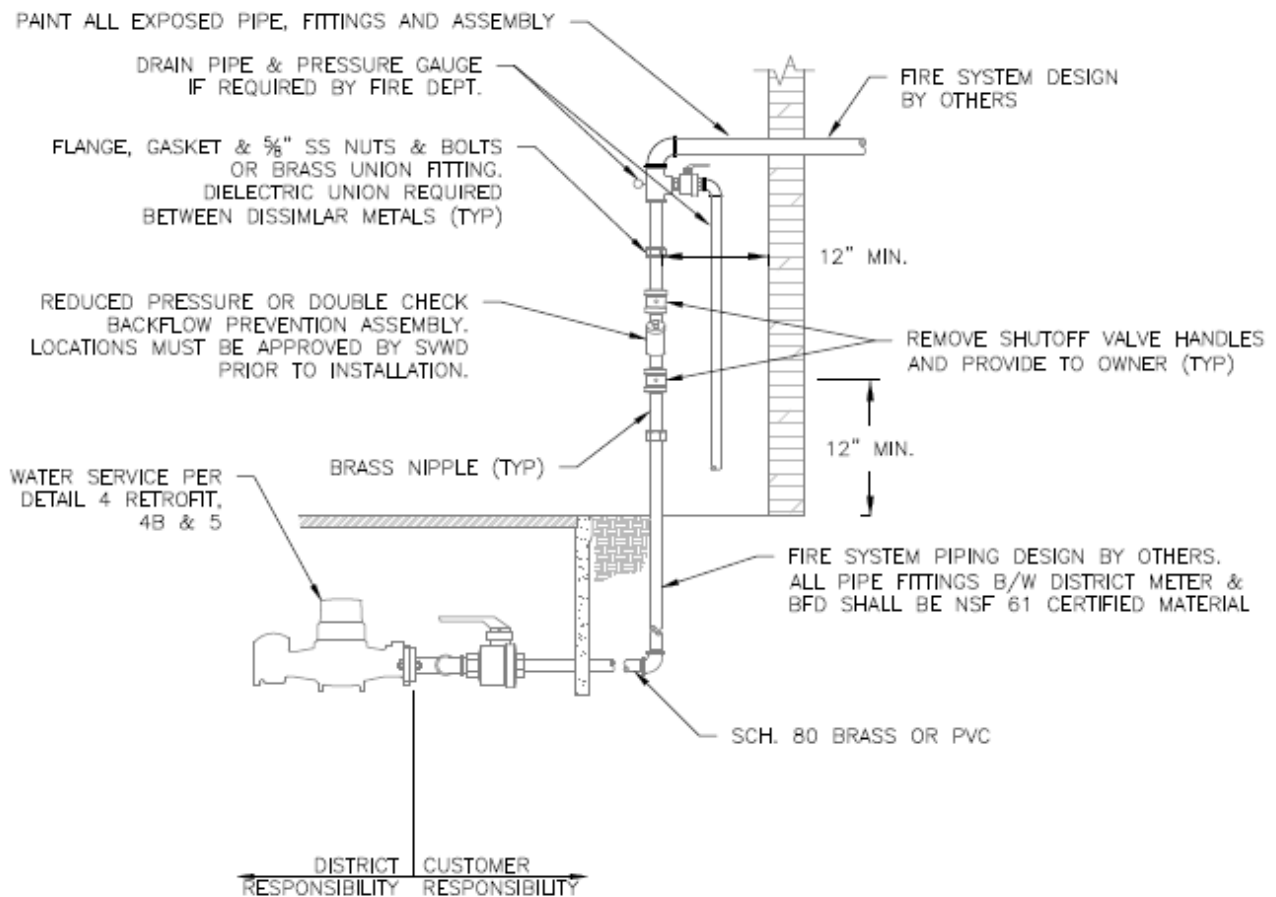

ELEVATION VIEW

NOTES

1. APPROVED BACKFLOW ASSEMBLY SHALL BE INCLUDED IN THE CURRENT "LIST OF APPROVED BACKFLOW PREVENTION ASSEMBLIES," FOUNDATION FOR CROSS-CONNECTION AND HYDRAULIC RESEARCH, USC, SCHOOL OF ENGINEERING. APPROVED ASSEMBLY SHALL BE INSTALLED SUCH THAT IT IS READILY ACCESSIBLE FOR REPAIR AND INSPECTION.
2. LOCATIONS MUST BE APPROVED BY SVWD PRIOR TO INSTALLATION
3. PAINT ALL EXPOSED PIPE, FITTINGS AND ASSEMBLY WITH 2-COATS OF RED COLORED RUST PREVENTATIVE ENAMEL.



SCOTTS VALLEY WATER DISTRICT
WWW.SVWD.ORG

DETAIL 9A

VERTICAL 2-INCH FIRE AND SMALLER
FIRE SERVICE BFD INSTALLATION

NOT TO SCALE

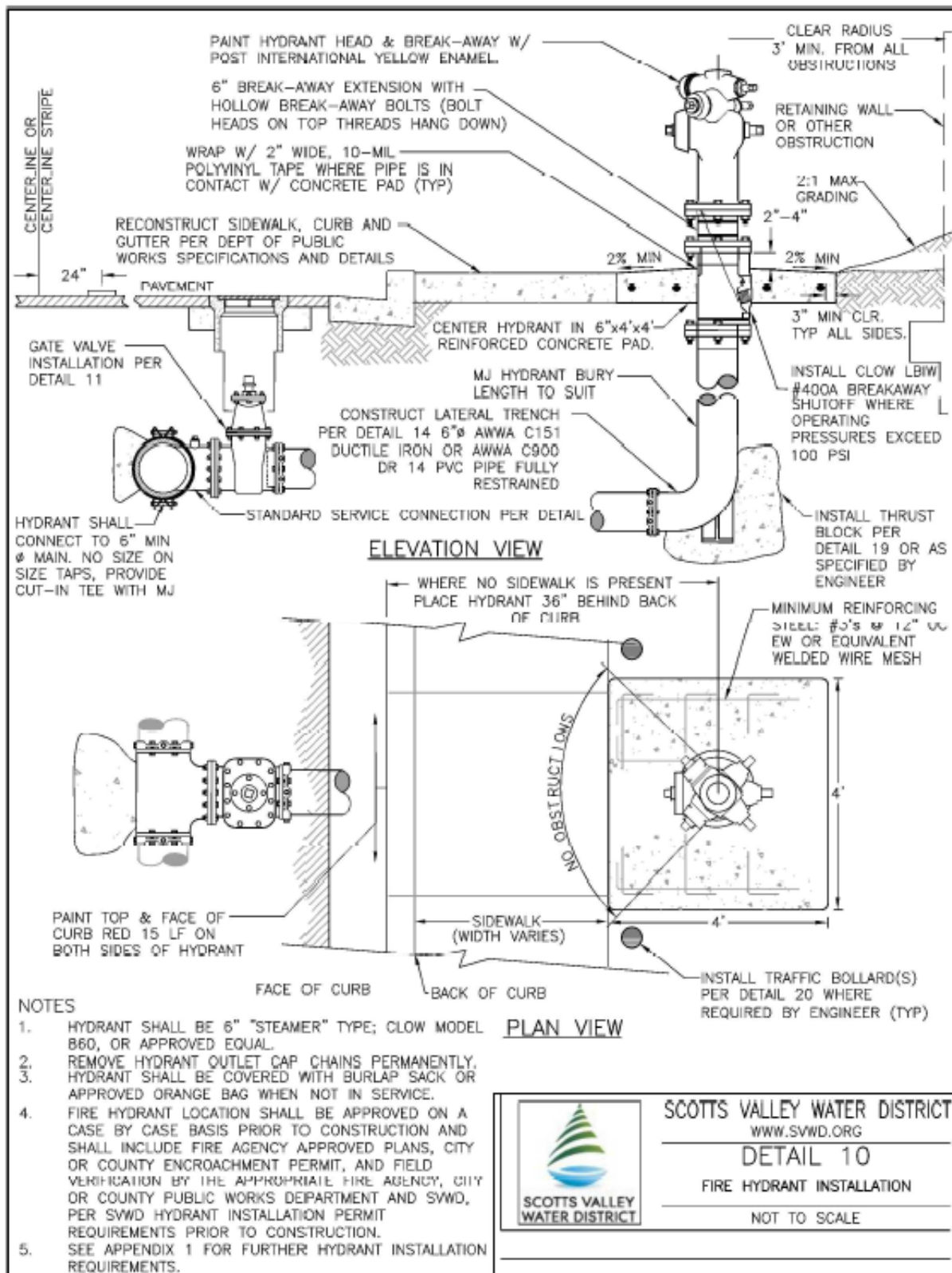

SCOTT'S VALLEY WATER DISTRICT
 WWW.SVWD.ORG
DETAIL 10
 FIRE HYDRANT INSTALLATION
 NOT TO SCALE

INSTALL CHRISTY G-5 VALVE BOX W/GSC LID OR EQUAL. VALVE BOX AND RISER CENTERED OVER GATE VALVE OR CORPORATION STOP VALVE AND ALIGNED WITH VALVE STEM AXIS. GRADE RINGS PROHIBITED

PROVIDE TESTING CONNECTION FOR TRACER WIRE

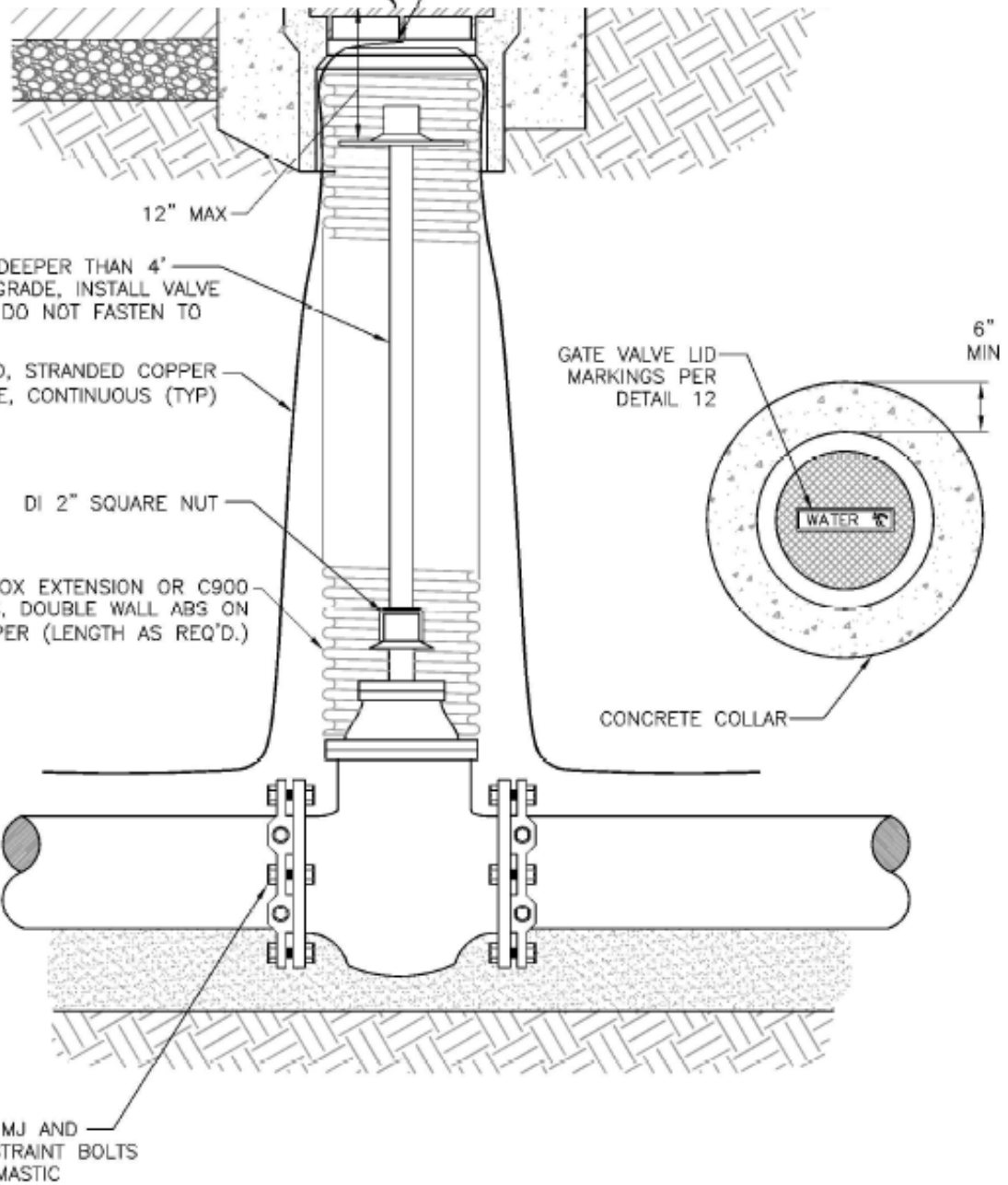

IF VALVE NUT IS DEEPER THAN 4' BELOW FINISHED GRADE, INSTALL VALVE NUT EXTENTION. DO NOT FASTEN TO VALVE NUT.

10 GA. COATED, STRANDED COPPER TRACER WIRE, CONTINUOUS (TYP)

DI 2" SQUARE NUT

PVC VALVE BOX EXTENSION OR C900 ON VALVES, DOUBLE WALL ABS ON COPPER (LENGTH AS REQ'D.)

GATE VALVE LID MARKINGS PER DETAIL 12

6" MIN

CONCRETE COLLAR

COAT ALL MJ AND JOINT-RESTRAINT BOLTS WITH BITUMASTIC

NOTES

1. INSTALL BLOCKING UNDER VALVE IF REQUIRED.
2. RISER TERMINATION FOR GATE VALVE SHALL OCCUR AT VALVE FLANGE.
3. RISER TERMINATION FOR SERVICE CONNECTION (2" & SMALLER) SHALL OCCUR 1" BELOW CORP STOP.
4. VALVE BOX LID SHALL BE OILED PRIOR TO PAVING OR CLEANING TO ENSURE THAT LID MARKINGS ARE LEGIBLE.
5. INSTALL VALVE BOX LID FLUSH WITH FINAL PAVING OR GROUND SURFACE.

 <p>SCOTTS VALLEY WATER DISTRICT</p>	<p>SCOTTS VALLEY WATER DISTRICT</p> <p>WWW.SVWD.ORG</p>
	<p>DETAIL 11</p>
	<p>GATE VALVE INSTALLATION</p>
	<p>NOT TO SCALE</p>

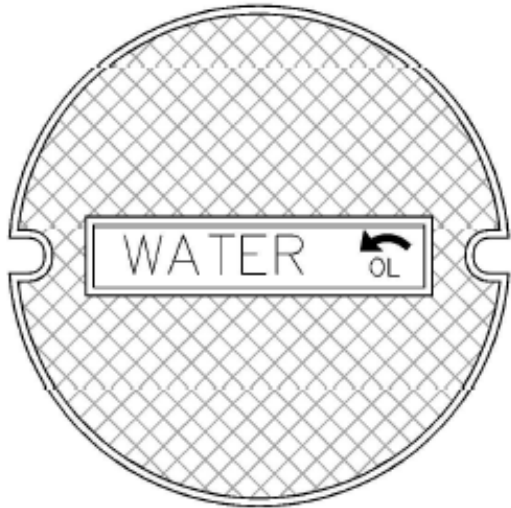

STANDARD VALVE BOX LID FOR MAIN LINE VALVES



STANDARD VALVE BOX LID FOR ALL NORMALLY CLOSED ZONE VALVES

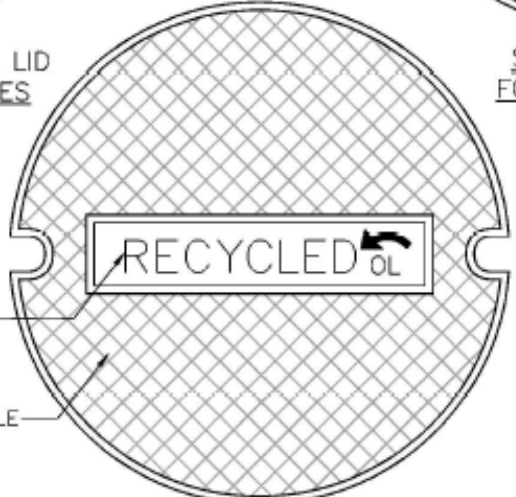

STANDARD VALVE BOX LID FOR RECYCLED WATER LINE VALVES

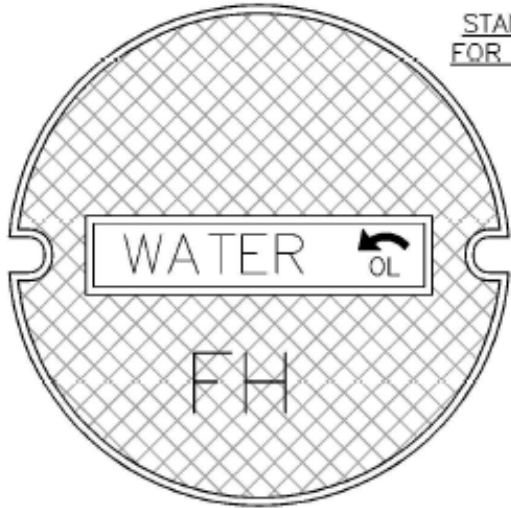

STANDARD VALVE BOX LID FOR ALL FIRE HYDRANT VALVES

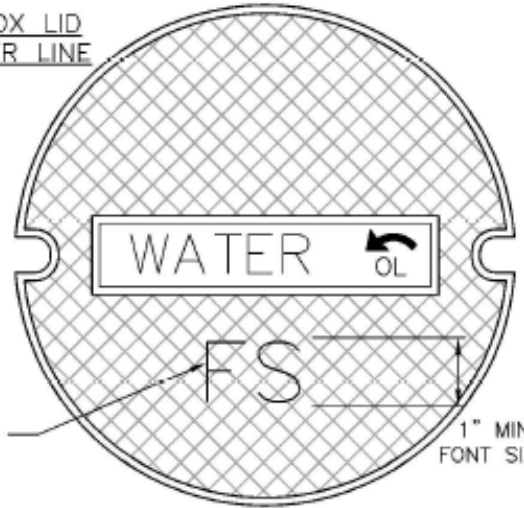

STANDARD VALVE BOX LID FOR ALL FIRE SERVICES

LABELING OPTIONS	LABEL	LID COLOR
BUTTERFLY VALVE	BFV	BLUE
BLOW OFF VALVE	BO	BLUE
TEST STATION	TS	BLUE
ZONE VALVE	ZV	BLUE
FIRE SERVICE	FS	BLUE
FIRE HYDRANT	FH	YELLOW
RAW WATER	RAW	TAN
RECYCLED WATER	REC	PURPLE



SCOTTS VALLEY WATER DISTRICT
WWW.SVWD.ORG

DETAIL 12

VALVE BOX LID MARKINGS

NOT TO SCALE

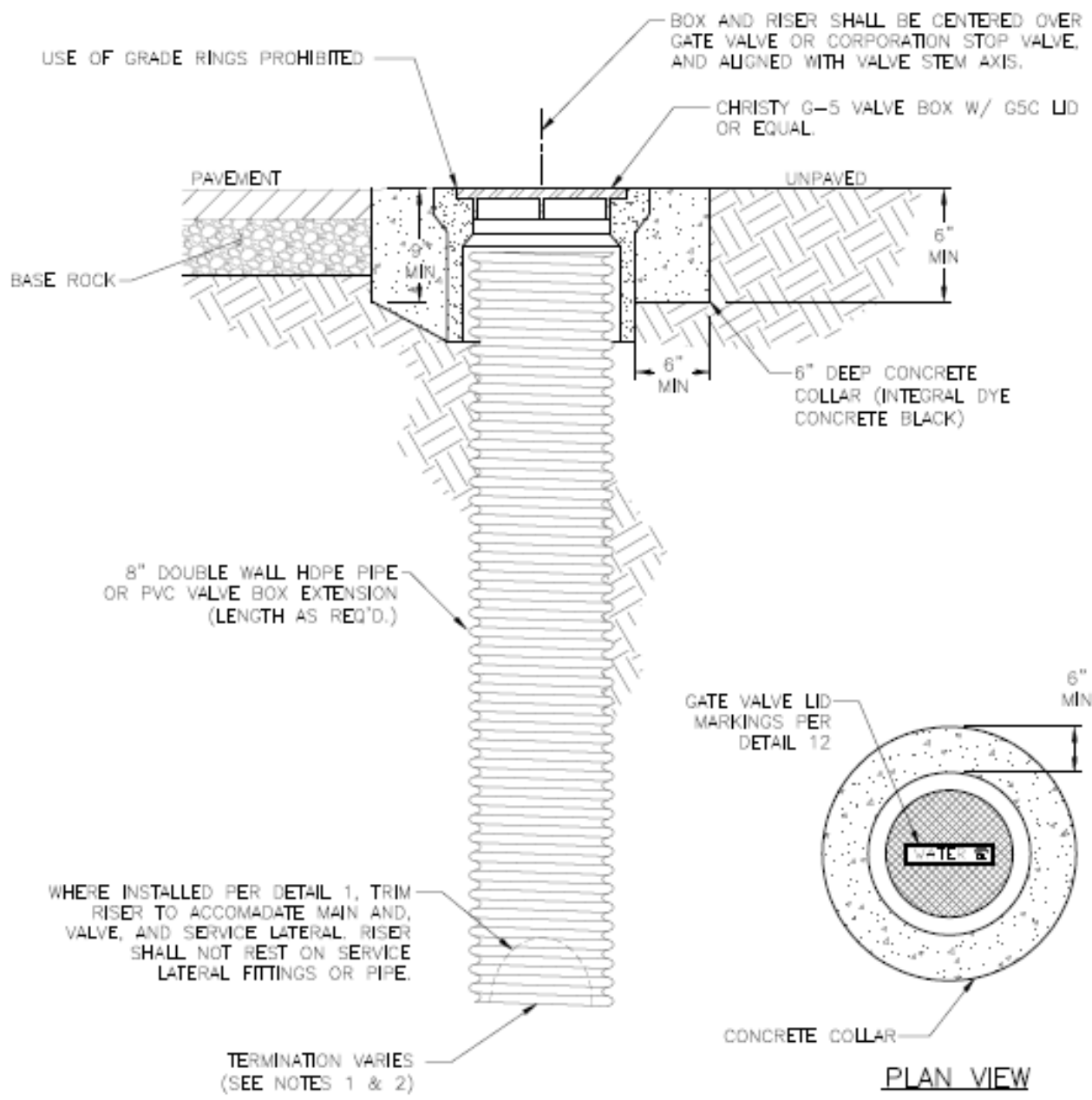

NOTES

1. RISER TERMINATION FOR GATE VALVE INSTALLATION SHALL OCCUR AT VALVE FLANGE (SEE DETAIL 11).
2. RISER TERMINATION FOR SERVICE CONNECTION (2" & SMALLER) SHALL OCCUR 1" BELOW CORP STOP.
3. VALVE BOX LID SHALL BE OILED PRIOR TO PAVING OR CLEANING TO ENSURE THAT LID MARKINGS ARE LEGIBLE.
4. INSTALL VALVE BOX LID FLUSH WITH FINAL PAVING OR GROUND SURFACE.



SCOTTS VALLEY WATER DISTRICT
WWW.SVWD.ORG

DETAIL 13

VALVE BOX INSTALLATION

NOT TO SCALE

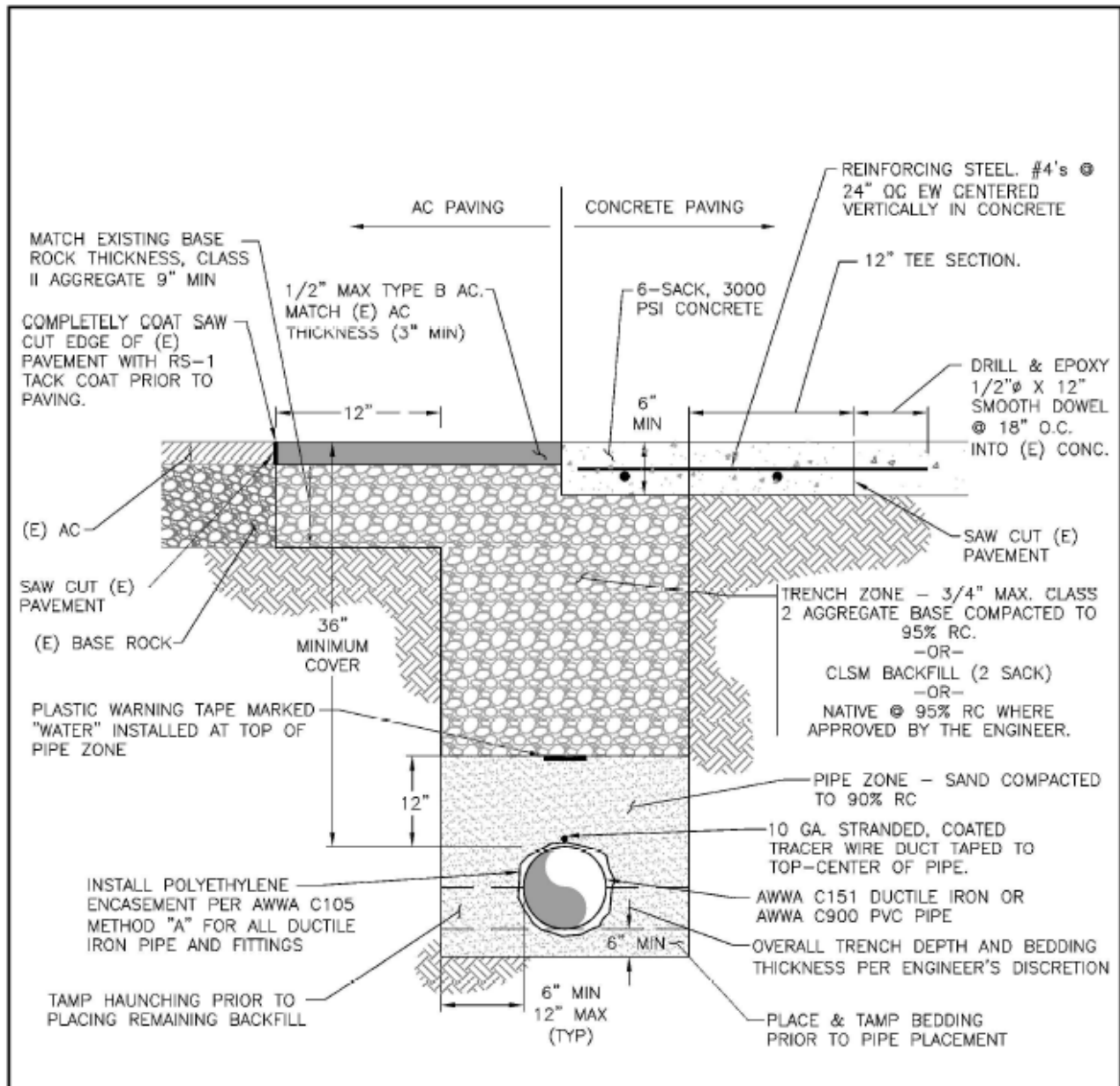

STANDARD WATER MAIN TRENCH

NOTES

1. IF ANY PORTION OF (E) PAVEMENT WITHIN SAWCUT LIMITS IS CONCRETE AT THE SURFACE, ENTIRE TRENCH SHALL BE RE-PAVED WITH CONCRETE AS SHOWN,
2. WHFRF WATER MAIN INSTALLATION CANNOT MEET MINIMUM COVER REQUIREMENTS, THE ENGINEER MAY APPROVE ALTERNATE INSTALLATION PER DETAIL 16.
3. REFER TO SVWD TECHNICAL SPECIFICATIONS FOR COMPACTION TESTING REQUIREMENTS.
4. FOR SERVICE LATERALS, REFER TO DETAIL 14.

 <p>SCOTTS VALLEY WATER DISTRICT</p>	<p>SCOTTS VALLEY WATER DISTRICT WWW.SVWD.ORG</p>
	<p>DETAIL 15</p>
	<p>STANDARD WATER MAIN TRENCH</p>
	<p>NOT TO SCALE</p>

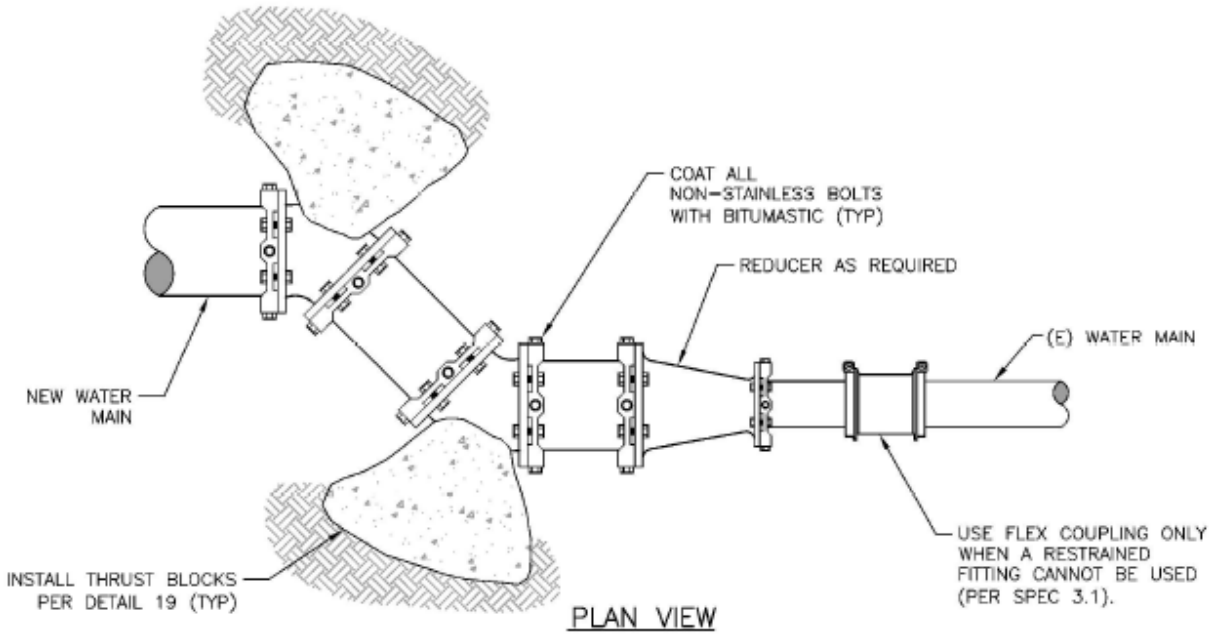
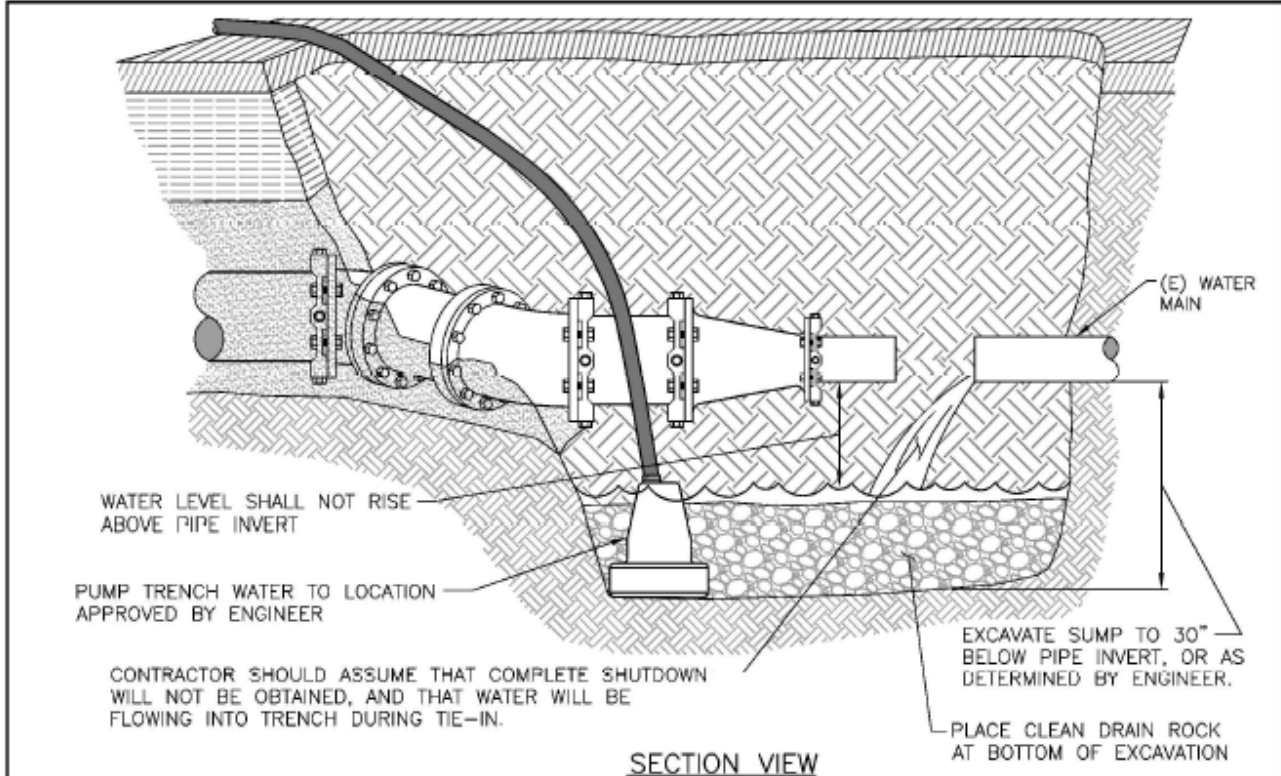

NOTES

1. CONTRACTOR SHALL VERIFY (E) MAIN DIAMETER PRIOR TO SCHEDULING SYSTEM SHUT DOWN.
2. ELBOWS SHARPER THAN 45° ARE NOT ALLOWED.
3. PIPE AND FITTING SIZES & MATERIAL SHALL BE SPECIFIED BY ENGINEER.
4. JOINT RESTRAINTS AND THRUST BLOCKING PER DETAILS 19 AND 20 ARE REQUIRED.
5. TEMPORARY THRUST BLOCKING MAY BE REQUIRED WHILE CONCRETE CURES.



SCOTTS VALLEY WATER DISTRICT
WWW.SVWD.ORG

DETAIL 17

SYSTEM CONNECTION (TIE IN)

NOT TO SCALE

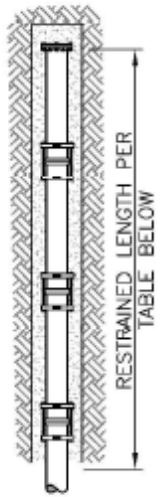

DIFFERENCE IN PIPE DIAMETER	REQUIRED RESTRAINT LENGTH (FT)
4"	35'
6"	45'
8"	60'
10"	75'
12"	90'

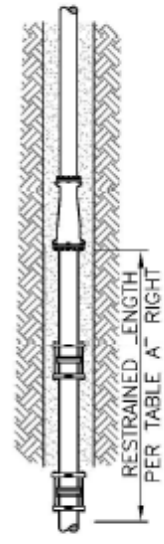

DIFFERENCE IN PIPE DIAMETER	REQUIRED RESTRAINT LENGTH (FT)
4"	25'
6"	50'
8"	65'
10"	80'
12"	100'

PLUG, CAP OR VALVE

REDUCER

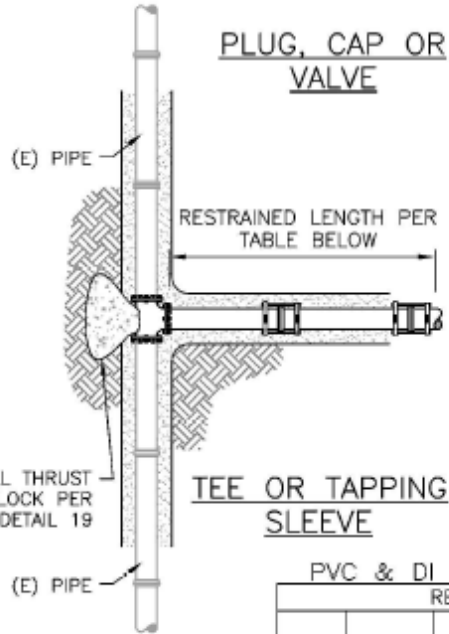

TEE OR TAPPING SLEEVE

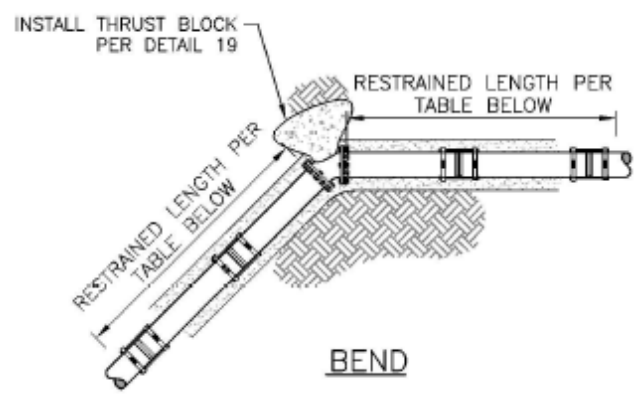

BEND

**PVC & DI PIPE JOINT RESTRAINT SIZING TABLE
REQUIRED RESTRAINT DISTANCE (FT.)**

PIPE DIA.	TEE BRANCH	VERTICAL BEND			HORIZONTAL BEND			
		11 1/2'	22 1/2'	45'	11 1/2'	22 1/2'	45'	90'
4	20	20	20	40	20	20	20	20
6	20	20	20	40	20	20	20	20
8	20	20	20	40	20	20	20	40
10	20	20	20	40	20	20	20	60
12	20	20	20	40	20	20	20	60

NOTES

1. ALL UNCOATED JOINT RESTRAINT AND FITTING HARDWARE SHALL BE COATED WITH BITUMASTIC.
2. THRUST BLOCKING PER DETAIL 19 IS REQUIRED.
3. SERVICE LATERALS SHALL BE FULLY RESTRAINED.



SCOTTS VALLEY WATER DISTRICT
 WWW.SVWD.ORG
DETAIL 18
 JOINT RESTRAINT INSTALLATION
 NOT TO SCALE

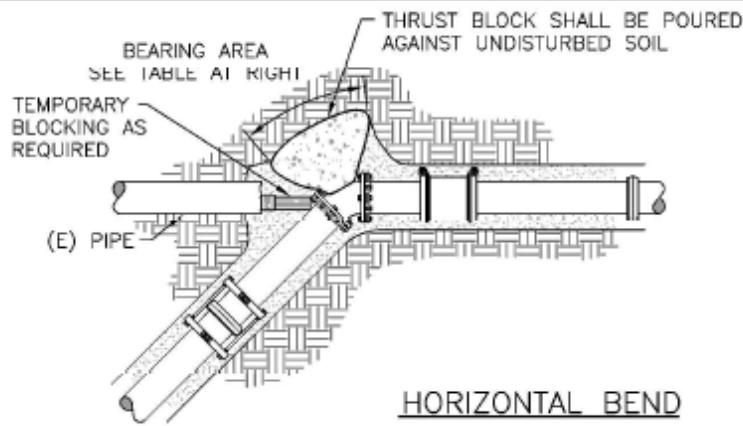

HORIZONTAL BEND

THRUST BLOCK BEARING AREA (SQUARE FEET)

		FITTING DEFLECTION			
		11 1/4'	22 1/2'	45'	90'
PIPE DIAMETER	4"	1	1	2	2
	6"	1	1	2	4
	8"	1	2	4	7
	10"	2	3	6	11
	12"	3	5	9	17

PIPE DIAMETER	BEARING AREA (SQUARE FEET)
4"	2
6"	3
8"	5
10"	9
12"	12

TEE

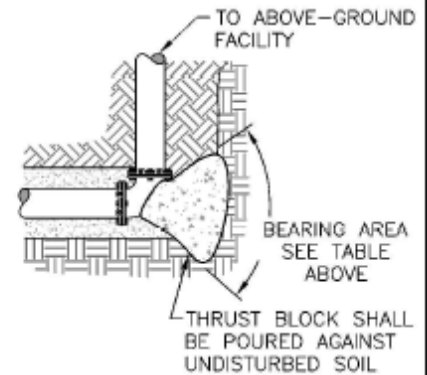
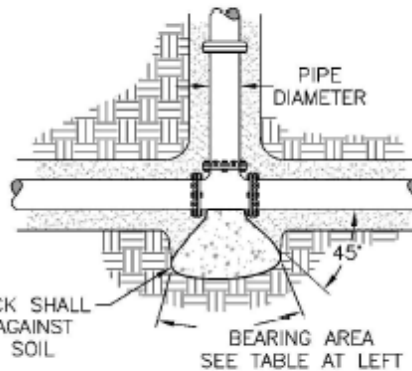

UPWARD VERTICAL BEND

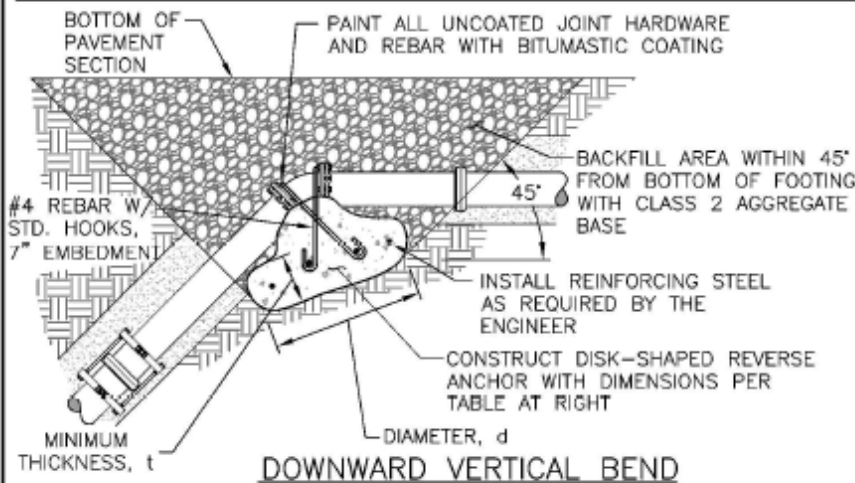

DOWNWARD VERTICAL BEND

MINIMUM REVERSE ANCHOR DIMENSIONS (FEET)

d / t	FITTING DEFLECTION		
	22 1/2'	45'	
PIPE DIAMETER	6"	2 / 0.5	3 / 0.5
	8"	3 / 0.5	4 / 0.8
	10"	3 / 0.5	5.5 / 2
	12"	4 / 0.5	9 / 2

NOTES

1. CONCRETE THRUST BLOCKS SHALL BE INSTALLED WHEN INDICATED BY THE CONTRACT DOCUMENTS OR AT THE DISCRETION OF THE ENGINEER.
2. THRUST BLOCKING IS REQUIRED WHERE IT IS UNKNOWN IF PIPE IS RESTRAINED, SUCH AS AT A CONNECTION TO EXISTING PIPE.
3. ALL CONCRETE SHALL BE 3000 PSI MINIMUM 28 DAYS COMPRESSIVE STRENGTH.
4. FOR PIPELINES LARGER THAN 10" IN DIAMETER, PIPELINES INSTALLED AT DEPTHS LESS THAN 36 INCHES, OR IN POOR SOILS, THRUST BLOCK DESIGN SHALL BE APPROVED BY THE ENGINEER ON A CASE BY CASE BASIS.





SCOTTS VALLEY WATER DISTRICT
WWW.SVWD.ORG

DETAIL 19

THRUST BLOCK INSTALLATION

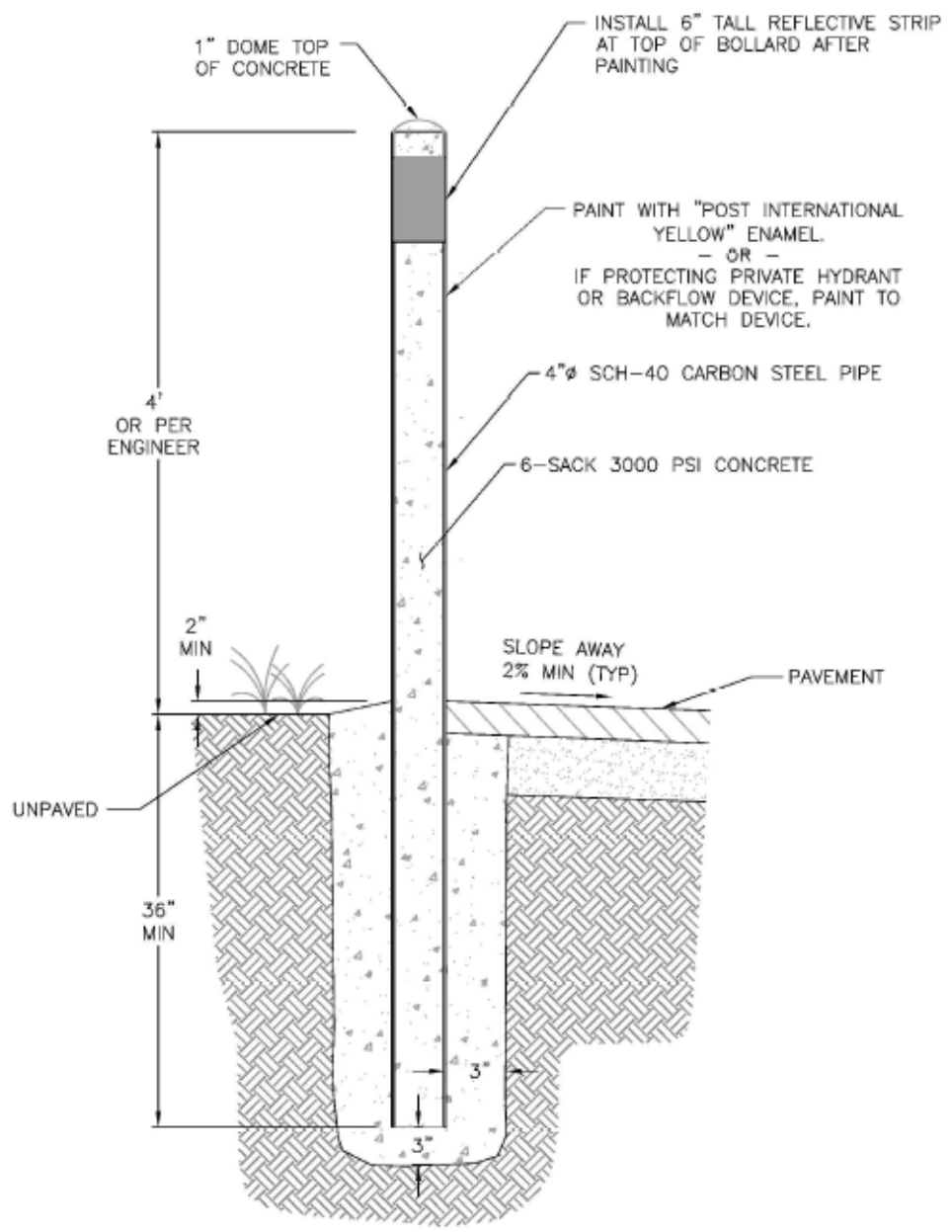
NOT TO SCALE



 <p>SCOTTS VALLEY WATER DISTRICT</p>	SCOTTS VALLEY WATER DISTRICT
	WWW.SVWD.ORG
	DETAIL 20
	TRAFFIC BOLLARD INSTALLATION
NOT TO SCALE	

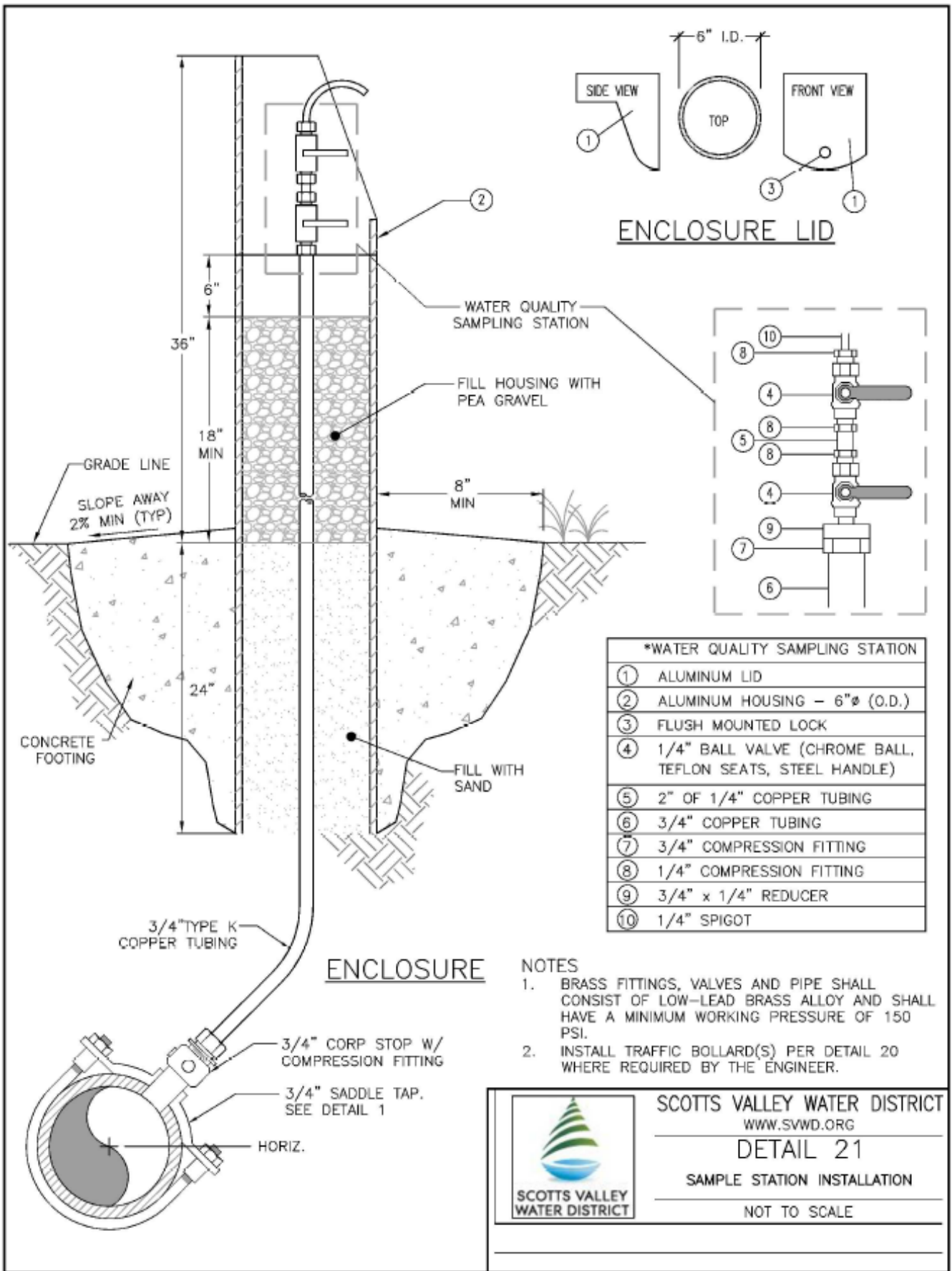

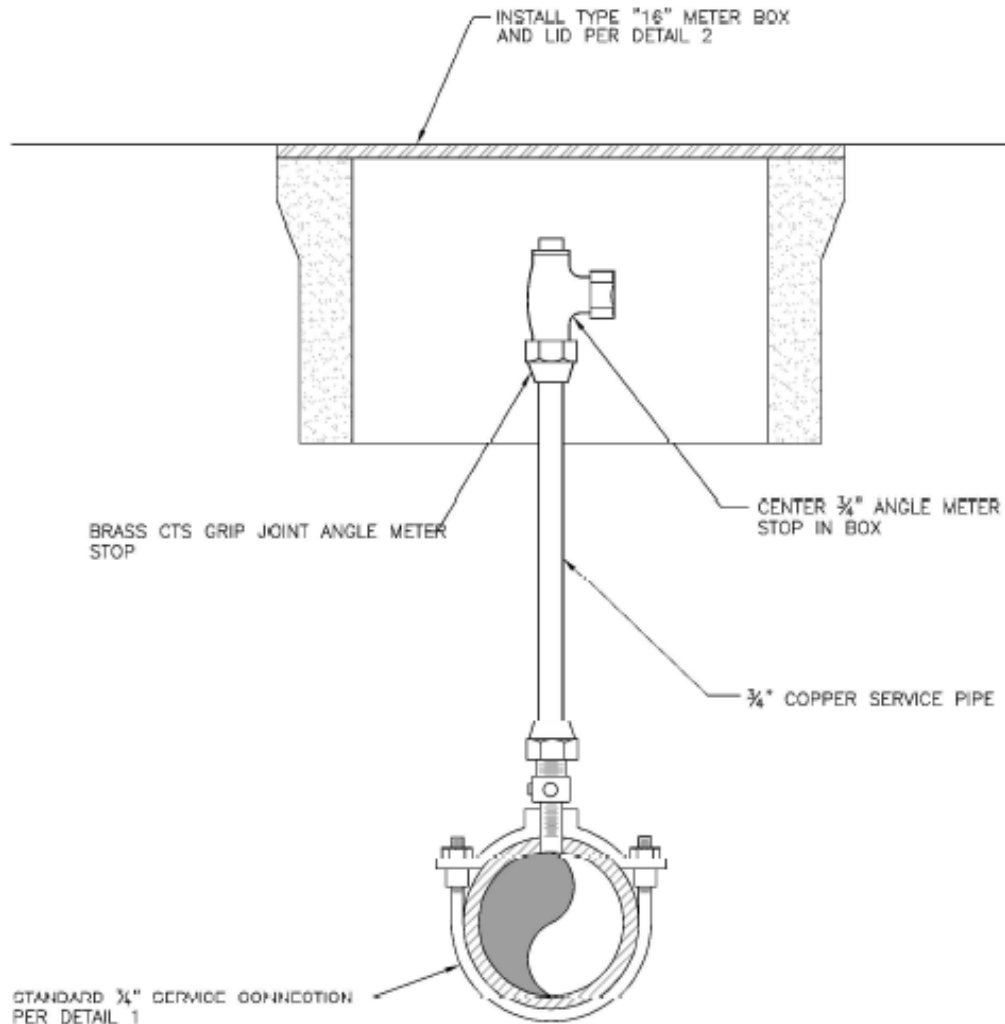

NOTES

1. BRASS FITTINGS, VALVES AND PIPE SHALL CONSIST OF LOW-LEAD BRASS ALLOY AND SHALL HAVE A MINIMUM WORKING PRESSURE OF 150 PSI.
2. CHLORINATION TAPS SHALL NOT BE LOCATED FURTHER THAN 10 FEET DOWNSTREAM OF THE BEGINNING OF THE NEW MAIN.
3. BOX SHALL BE LOCATED AS INDICATED BY CONTRACT DOCUMENTS OR THE ENGINEER.
4. AFTER DISINFECTION, CLOSE AND CAP CORPORATION STOP AND REMOVE ALL COMPONENTS.



SCOTTS VALLEY WATER DISTRICT
WWW.SVWD.ORG

DETAIL 22

CHLORINATION TAP INSTALLATION

NOT TO SCALE

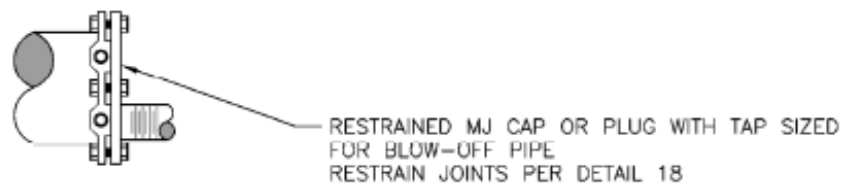
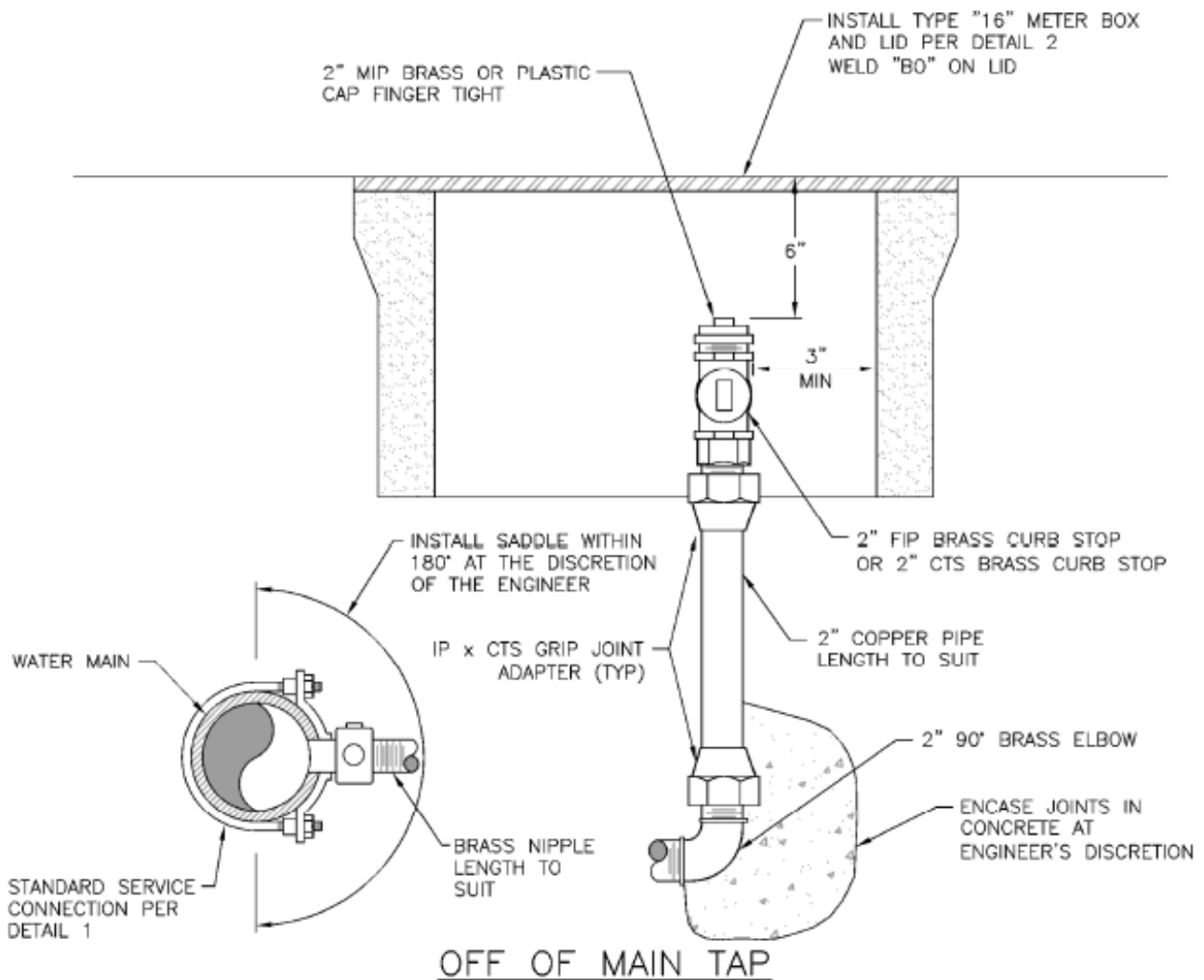

NOTES

1. BLOW-OFF ASSEMBLY MUST BE RESTRAINED, INCLUDING TEMPORARY INSTALLATIONS.
2. MODIFICATIONS MAY BE PERMITTED AT THE DISCRETION OF THE ENGINEER FOR TEMPORARY INSTALLATIONS.
3. BRASS FITTINGS, VALVES AND PIPE SHALL CONSIST OF LOW-LEAD BRASS ALLOY AND SHALL HAVE A MINIMUM WORKING PRESSURE OF 150 PSI.
4. WRAP ALL FITTINGS & PIPE W/ 2" WIDE, 10-MIL PIPE TAPE WHERE IN CONTACT W/ CONC. THRUST BLOCK

 <p>SCOTTS VALLEY WATER DISTRICT</p>	<p>SCOTTS VALLEY WATER DISTRICT</p> <p>WWW.SVWD.ORG</p>
	<p>DETAIL 23</p>
	<p>BLOW OFF INSTALLATION</p>
	<p>NOT TO SCALE</p>

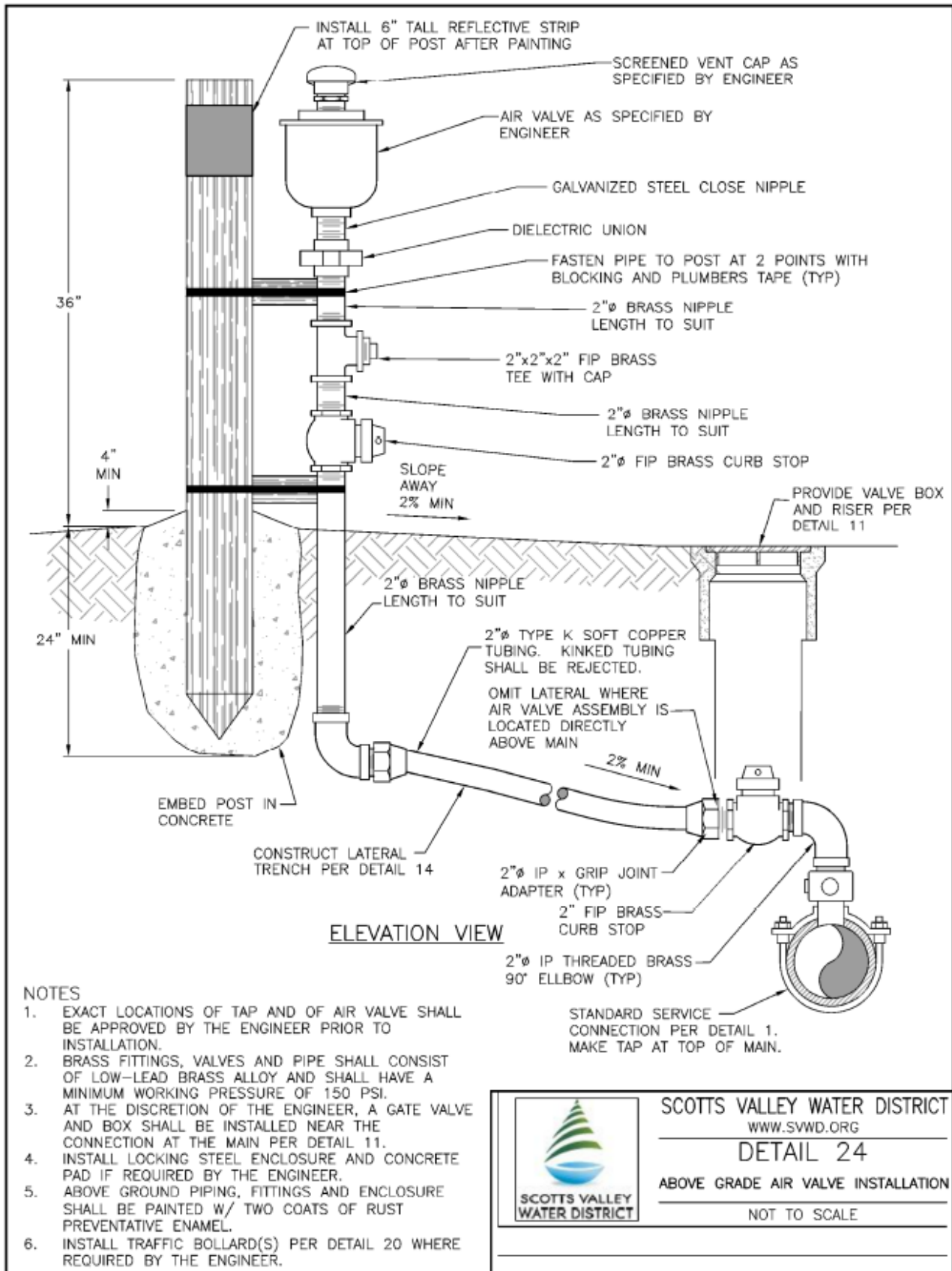

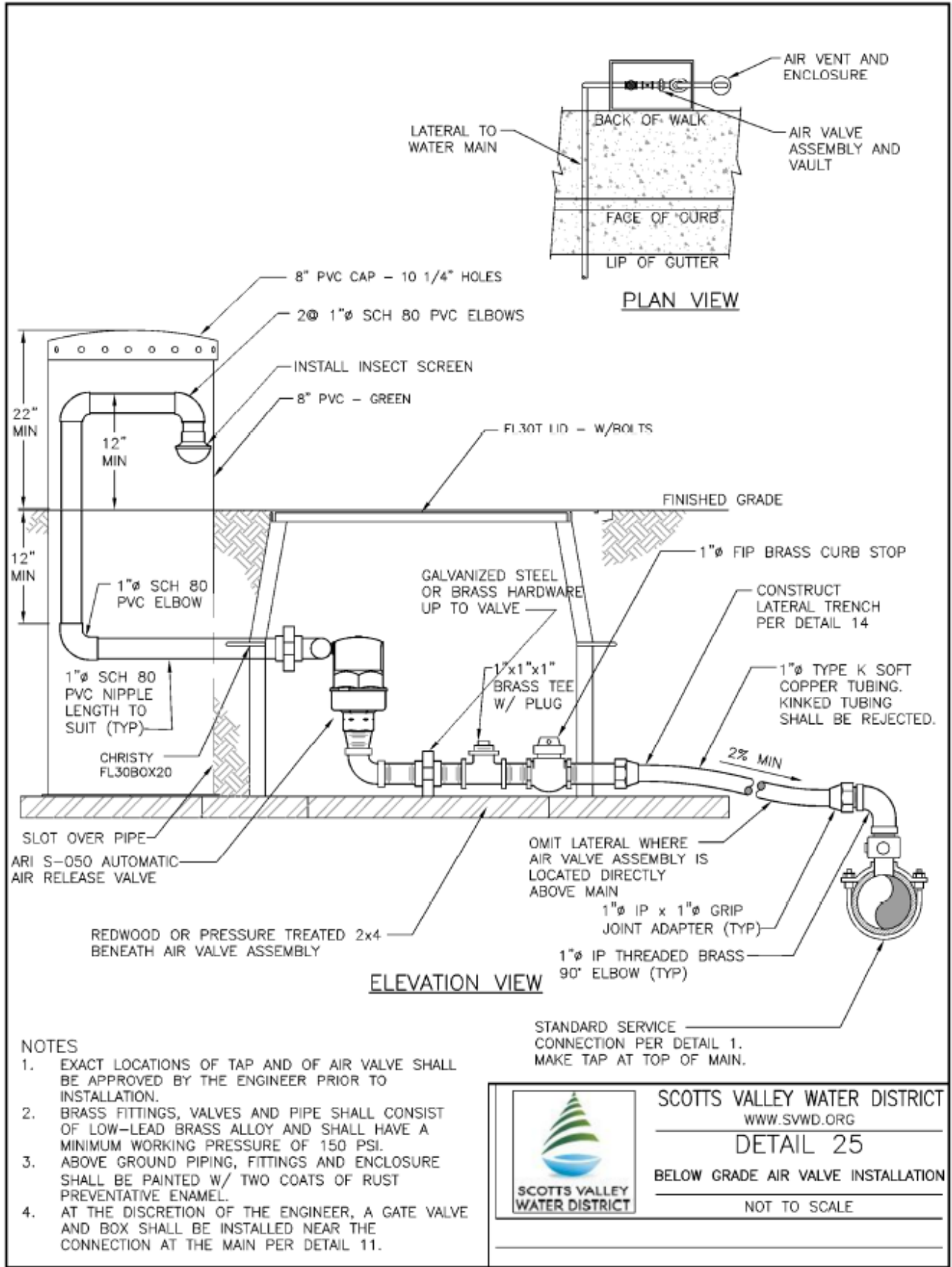

APPENDIX 1

Hydrant Installation Permit Requirements

In addition to complying with the Scotts Valley Water District Standard Specifications, latest revision, regarding the construction of fire hydrants, applicant must receive approval of fire hydrant location prior to beginning construction. Approval is on a case by case basis and shall include District-approved plans, Scotts Valley Fire approved plans, City and/or County encroachment (street opening) permits, and field verification by the Scotts Valley Fire Protection District and SVWD.

In general, the following criteria shall be met:

1. General Location Requirements:
 - a. Hydrant lateral length shall be minimized by locating on the short side of the water main.
 - b. Hydrant head shall not be allowed within a curb-line projection to avoid conflicts should the curb be extended in the future.
 - c. Where hydrant will be located behind the sidewalk or outside of concrete area, hydrant shall be positioned at the center of a minimum 36"x36"x4" concrete pad with 6"x6"-W4xW4 reinforcement.
 - d. Location shall have minimal impact on neighborhood parking sites.
 - e. When permissible, mid-block locations shall be placed at property lines. When this is not possible, property owners shall be notified to establish public relations and acceptance of hydrant location.
 - f. Hydrant should not be located below power lines.
 - g. Where possible, hydrants should be placed behind the back of walk.
2. Setbacks/Offsets/Clearances:
 - a. For sidewalks wider than 6', center hydrant 9" behind back of curb. For sidewalks less than 6', hydrant position must be approved by the appropriate agencies including SVWD, City or County Public Works Department, and Scotts Valley Fire Protection District.
 - b. For all installations, a minimum of 3' radius around all sides of hydrant shall be clear of private property lines, walls, poles, or any other vertical obstructions to facilitate fire agency hookup. Plans shall show relevant parcel boundaries, public or private right of ways and easements.
 - c. If an easement is required for the hydrant location and clearances, the applicant shall prepare the easement using the District's format and language and obtain any necessary survey information. The District shall review and approve the easement before it is finalized.
 - d. For all installations in sidewalks, a minimum of 4' clear sidewalk width around one side of the hydrant shall be maintained for A.D.A. compliance.
 - e. Center hydrant head a minimum of 10' from driveway pans.
 - f. Location shall be outside the drip line of existing mature trees, consider proximity of young trees. Location shall be set back 4' minimum from mature shrubs, consider proximity of young shrubs.